

"SLIM SHOT"

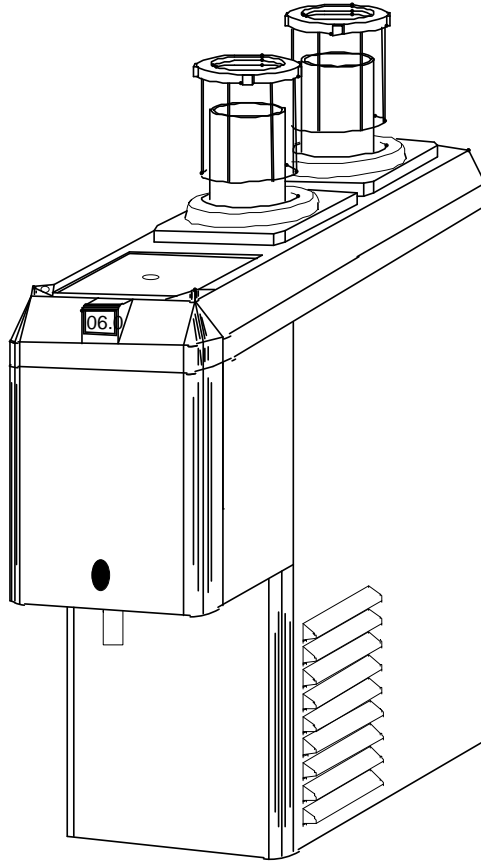

Installation and Service Manual

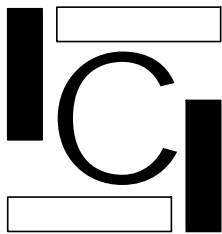

INTERNATIONAL CARBONIC INC.

16630 Koala Rd.

Adelanto, California 92301

800 854-1177

IMPORTANT: This manual is a guide for installing, operating, servicing and maintaining this equipment. Refer to Table of Contents for page location of detailed information to answer questions that arise during installation, operating, service and maintenance, or installation of this equipment.

TABLE OF CONTENTS

	PAGE
PREFACE	1
CHAPTER 1	
GENERAL DESCRIPTION.....	2
SYSTEM DESCRIPTION	2
DESIGN DATA	2
THEORY OF OPERATION.....	3
EXPLODED VIEW	4
EXPLODED VIEW DESCRIPTION	5
ELECTRIC SCHEMATIC.....	6
CHAPTER II	
UNPACKING AND INSPECTION.....	7
SELECTING LOCATION.....	7
LOCATION RECOMMENDATIONS	7
ELECTRICAL REQUIREMENTS.....	7
UNIT INSTALLATION INSTRUCTIONS.....	8
UNIT INSTALLATION INSTRUCTIONS PAGE 2.....	9
CHAPTER III	
OPERATORS INSTRUCTIONS	10
DAILY PRE-OPERATION CHECK.....	10
COOLING UNIT MAINTENANCE.....	10
CLEANING DISPENSING TUBE.....	10
CLEANING CONDENSER COIL.....	11
FLUSHING LIQUOR COIL	11
CLEANING AND SANITIZING.....	12
NOTES.....	13

PREFACE

INTERNATIONAL CARBONIC INC. has enjoyed over 56 years of manufacturing excellence in the field of carbonation and in the beverage related industry. We have been located in the Southern California area since 1952 and have a long and proud history with quality as our standard and innovation as our goal. Originally started just after World War II in Canfield Ohio as Carbonic Dispensers we enjoyed patents on the first Sodajet type carbonator. This method of carbonation instantaneously carbonated the water to 100% saturation. We developed the first patented dispensing valve to dispense bulk beverage with carbonation equal to or in excess of bottled beverages. A valve with three flavors and soda was another first. We were the first to incorporate the total post-mix package; i.e., carbonation, refrigeration & the ability to dispense from one self contained unit. We have pioneered many such firsts and will continue to develop advance systems for the future, such as electronic interrogatable portion controls to electronic liquid level controls.

We hope you enjoy this product that has been produced to give many years of trouble free service. We thank you for your purchase and hope we may serve you in the future.

SLIM SHOT

CHAPTER I

GENERAL DESCRIPTION

This chapter gives the description, theory of operation, and design data for the SLIM SHOT unit.

SYSTEM DESCRIPTION

The SLIM SHOT unit is a complete self-contained liquor dispenser that will dispense a shot of liquor that is colder than ice. The unit consists of a cabinet, refrigeration system, modular pump/s, and LED lights for merchandising. The cabinet is housed in attractive black vinyl coated steel with vibrant custom decals. The front plate and switch housing are formed from attractive grained stainless steel. The SLIM SHOT unit has been designed to fit in the smallest possible space while dispensing a maximum amount of chilled liquor.

Essentially the SLIM SHOT unit is designed to plug and play. For proper function the SLIM SHOT unit must have 115-volt electrical supply and proper space around the unit to allow the refrigeration to breathe during operation.

DESIGN DATA

Cabinet:

Height	23
Width.....	8 ½
Depth	16
Depth w/Switch Housing.....	18 ¾

Weights:

Shipping.....	60 LBS.
Operational weight.....	54 LBS.

Refrigerant requirement (R-134a)	1.94 ounces
Refrigerant requirement (R-134a)	55 grams

Ambient operating temperature	40 F to 100 F
-------------------------------------	---------------

Electrical Requirements:

The cooling unit requires a 115-VAC, single phase, 60-Hertz power circuit.

Circuit Ampacity.....	3.5 Amps
-----------------------	----------

Compressor	2.2 Amps
Liquor Pump	0.98 Amps
Condenser Fan	0.25 Amps

REFRIGERATION 1/9 H.P. capillary air-cooled.

THEORY OF OPERATION

The SLIM SHOT unit was designed to cool and dispense a chilled serving of liquor using a minimum amount of counter space. After connecting the unit to an electrical outlet and after placing the liquor bottles in the bottle reservoirs. Depress the push button switch to dispense a small portion of liquor. In approximately 45 minutes from the time the unit is electrically activated the unit will dispense a chilled liquor shot between 5 to 10 degrees.

When the Push Button Switch is pushed the incoming liquor is routed to a through the pump, and then through a cooling coil that is housed in an aluminum cold plate. This aluminum cold plate also houses our refrigeration evaporator turning the aluminum cold plate into an extension of the evaporator. This evaporator assembly is thoroughly insulated. The temperature of the incoming liquor is at ambient temperature as it enters the cooling coil. As the incoming liquor passes through the cooling coil the heat is removed from the liquor and chilled to a temperature acceptable for a quality cold shot, normally a temperature of 5 to 10 degrees. The liquor is now directed to a dispensing tube where the liquor is dispensed.

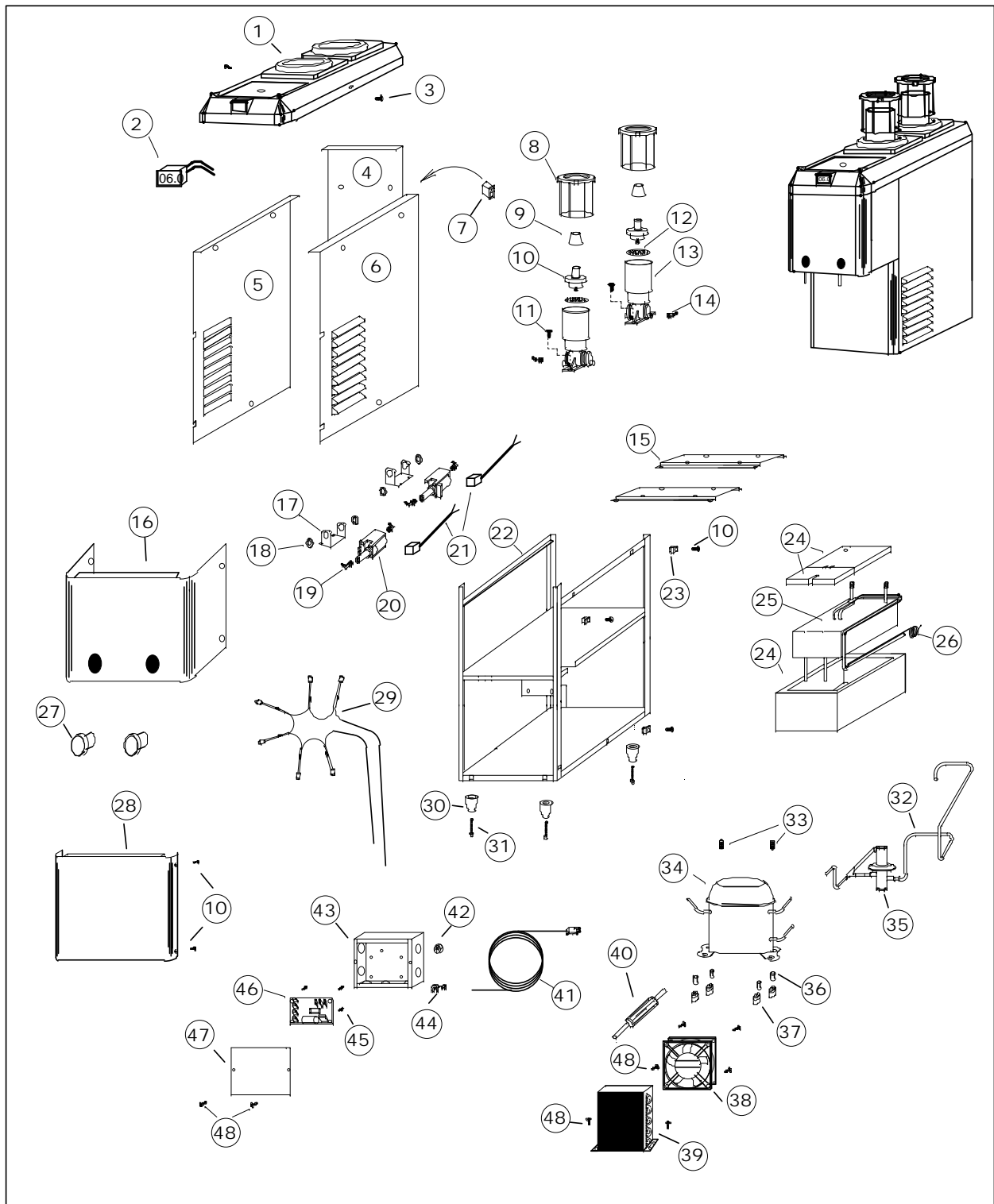

ICI International Carbonic Inc Adelanto, California	Unit: Slim Shot	Drn By: JGS
	Item No: NSS-2	Ck By: LL
	Spl No: 2 Brand	Date: 6/10/08

SLIM SHOT

SYM	QTY	PART NO.	DESCRIPTION	SYM	QTY	PART NO.	DESCRIPTION
1	1	S1892	Top Cover	25	1	S1834-CP-SS-2	Cold Plate, Slim Shot, 2 Brand
2	1	S1911	Digital Thermometer	26	1	Z0009	Cap Tube, 12' - .042
3	2	A0063	Screw, 8-32 x 3/8" Phil. T.H. M/S Black Oxide	27	1	S1910	Push Switch
4	1	S1922	Service Panel, Rear	28	1	S1921	Front Panel, S.S.
5	1	S1923	Service Panel, Left	29	1	S1912	LED Wire Harness
6	1	S1924	Service Panel, Right	30	4	S1598	Leg, Slim Shot
7	1	S0783	Switch, ON/OFF	31	4	A0013	Screw, #8 X 1" HWH. SMS.
8	2	12074	Bottle Support Assembly	32	1	S1838-SS	Hot Gas Bypass Discharge Valve Assembly
9	2	18018	Sleeve, Bottle Cap, (LARGE)	33	4	A0047	Screw, 5/16-18 x 1", H.H. Flange
10	2	12008-CS	Bottle Cap Assembly, Chill Shot	34	1	AZA0370YXA	Compressor, 1/9th h.p.
11	30	A0014	Screw, #10 X 1/2 P.H. T.H. S.S.	35	1	S1839	Hot Gas Bypass Discharge Valve
12	2	18013-CS	Strainer, Reserve, Perforated S.S.	36	4	N0071	Sleeve, Compressor Mounting
13	2	12004-1/4-R	Bottle Reserve Replacement For Chill Shot	37	4	N0046	Grommet, Compressor Mounting
14	2	18020	Elbow, Reserve 1/4P X 1/4H, Plastic	38	1	S1908	Fan, Condenser
15	2	S1836-SS	Bottle Reserve Mounting Bracket	39	1	S1909	Condenser
16	1	S1920	Switch Housing	40	1	S1545	Drier, Refrigerant
17	2	S1904	Bracket, Pump Mounting	41	1	E0141-8-CS	Power Cord, 8 ft.
18	2	S1903	Grommet, Pump Mounting	42	7	S0046	Bushing, Universal
19	2	S1902	Elbow, Pump Inlet/Outlet 1/8P X 1/4H, Plastic	43	1	S1916	Control Box, Slim Shot
20	2	S1900	Pump, Oscillating Piston	44	1	E0664	Strain Relief
21	2	S1901	Plug/Wire/Diode	45	4	S1335	Spacer, Control Board
22	1	S1915	Frame	46	1	S1950-SS	Control Board
23	34	S1325	Nut, Square Grommet, Nylon	47	1	S1917	Control Box Cover
24	1	S1846	Insulation Set	48	8	A0020	Screw, 8-32 X 3/8 T.H. S.S.

SLIM SHOT

CHAPTER II

INSTALLATION

This chapter covers the unpacking and inspection, selecting a location, electrical requirements and installing your SLIM SHOT unit.

UNPACKING AND INSPECTION

Upon receiving unit, immediately remove your SLIM SHOT unit from the shipping carton and inspect for shipping damage.

NOTE: Remove the SLIM SHOT unit from the shipping carton and inspect for shipping damage. If shipping damage is found immediately contact Sentry BevCon at (800) 661-3003. Do not discard the shipping carton or any shipping materials in the event a freight claim must be filed.

SELECTING LOCATION

IMPORTANT: Ambient temperature for cooling unit should not exceed 100 degrees "F". Operation of cooling unit in ambient above 100 degrees "F" can and will contribute to early failure of condensing unit and poor quality of finished product.

LOCATION RECOMMENDATIONS FOR THE SLIM SHOT UNIT

1. Position unit as close as possible to proper electrical source, 120V 60Hz.
2. Position unit with a minimum of 2" space between bulkhead and cabinet for sufficient space for ventilation. Allow enough space between ceiling and unit for bottle removal.

LOOSE - SHIPPED PARTS

Qty.	Item No.	Description
1	-----	Installation instructions
2	12008-CS	Bottle Cap Assembly
2	18013-CS	Strainer
2	*	Sleeve to fit Bottle

*(Small #18014, Medium #18016, Med/Large #18017, Large #18018, Ext Large #18011)

ELECTRICAL REQUIREMENTS:

The SLIM SHOT unit must be wire in accordance with N.E.C. or local ordinance.

"SLIM SHOT"

Installation Instructions

Remove the SLIM SHOT chiller from the shipping carton and inspect for shipping damage. If shipping damage is found immediately contact Sentry BevCon at 800 661-3003. Do not discard the shipping carton or any shipping materials in the event a freight claim must be filed.

1. The following parts are included with this Shipment.
2. Find a convenient location to place your "SLIM SHOT" chiller.
3. DO NOT PLUG YOUR UNIT INTO AN ELECTRICAL OUTLET AT THIS TIME.

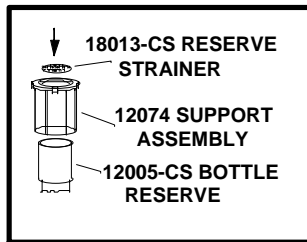
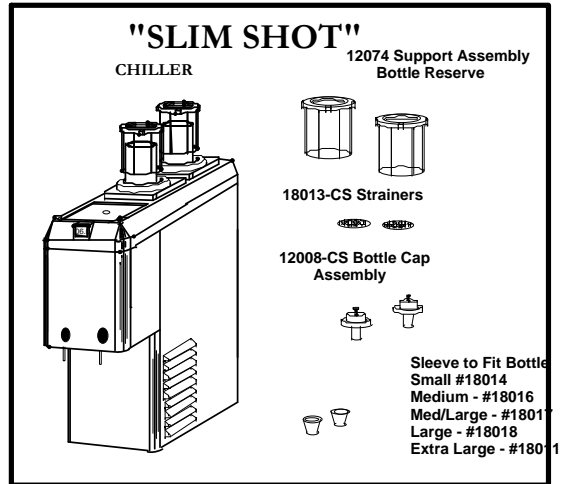

4. Install both stainless steel strainers in bottle reserves.

5. Slip the sleeves over bottle caps then slip these assemblies into the liquor bottles.

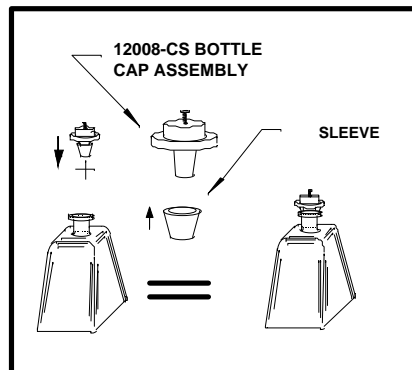

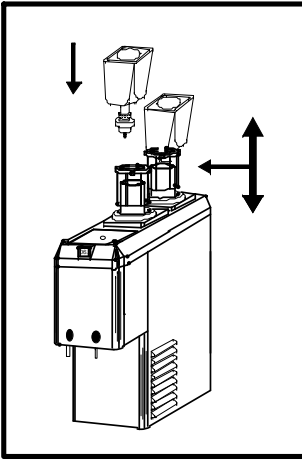

6. Turn the Liquor bottles upside down and place them into the bottle reserves. Adjust the support assemblies to stabilize the bottles.
7. Plug the unit into a 110 volt outlet. The refrigeration system will automatically start. If refrigeration does start go to step #11.
8. Activate the "PUSH" switch until the liquor is dispensed. The level of the liquor in the bottles will drop as the cooling coils are filled. Dispense 6 to 8 ounces in order to flush the unit.
DO NOT REUSE THIS LIQUOR!

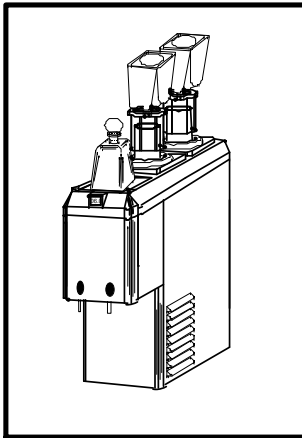

9. In approximately 45 minutes the unit will dispense ice-cold liquor shots.

10. Place a Liquor bottle in the top front-lighted bottle tray for merchandising.

11. Your unit is equipped with an on/off switch for the refrigeration. This switch should be in the on position during normal operation. Only put switch in the off position for flushing/cleaning. If unit does not chill check to make sure switch is in the on position.

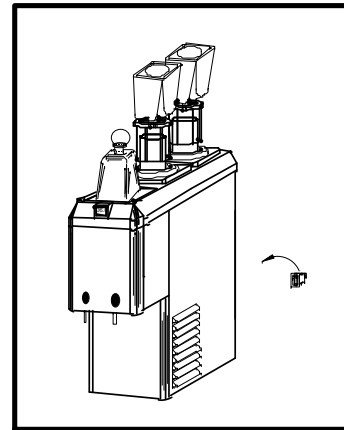

Note: to increase your customers enjoyment cool your shot glasses before serving shots.

**For Service and/or Installation Assistance
Please Call Sentry BevCon
800 661-3003**

5/22/08

SLIM SHOT

CHAPTER III

OPERATORS INSTRUCTIONS

This chapter covers operators' responsibilities for daily pre-operation check, adjustments, cleaning, and sanitizing.

DAILY PRE-OPERATION CHECK

1. Make sure reservoir is full and ready to dispense.
2. Make sure electrical power is supplied to unit.
3. Make sure unit is clean.

COOLING UNIT MAINTENANCE

NOTE: Air circulation through the unit is required to cool the condenser/compressor and is drawn in through vents on the side of the unit, through the condenser and is exhausted out vents on the rear of the unit. Restricting air circulation through the cooling unit will decrease its cooling capacity.

To avoid needless and sometimes costly repairs, it is imperative to keep condenser fins clean. This may be accomplished by using a condenser brush (a longhaired, soft bristle brush) and/or a vacuum to gently sweep fins of condenser clean and vacuum dust and dirt away.

CLEAN DISPENSING TUBE

Use a damp towel and clean tube nightly.

PERIODIC INSPECTION AND CLEANING

Daily:

1. Clean bottles and reservoir area with warm water.
2. Clean the beverage dispensing area.
3. Clean dispensing tube and all exposed areas on front plate.
4. Wipe exterior of unit with moist towel.

Weekly:

1. Check condenser coil for obstructions or dirt.

Monthly:

1. Clean condenser fins or filter to make sure the refrigeration unit has adequate airflow.
2. Check entire system for leaks or damaged components. Repair as necessary.

DO NOT USE ABRASIVE TYPE CLEANERS.

CLEANING CONDENSER COIL

IMPORTANT: Air circulation through the condenser coil required to cool the condenser coil/compressor, is drawn in through grills on cooling unit, through condenser coil and exhausted out grills on the other side of unit. Restricting air circulation through the cooling unit will decrease its cooling capacity.

NOTE: *Cleaning condenser coil should be done during non-business hours.*

1. Unplug refrigeration unit power cord from electrical socket.
2. Remove the screws securing the front and side service panels, remove panels in preparation for service.
3. Vacuum or use a soft brush to clean fins of condenser coil.
4. Replace panels.
5. Plug refrigeration unit power cord in electrical socket.

FLUSHING LIQUOR COIL

It is recommended to flush the Liquor Coil periodically. To accomplish this task shut off the refrigeration system at the on/off switch located on the rear service panel.

Flush all liquor out of liquor coil and into a container to be reused.

After condensing unit has been off for at least one hour fill liquor reservoir with hot water and flush through coil. Flush coil until water comes out clear.

Refill reservoir with saved liquor and flush all water out of liquor coil.

When all water is flushed out of system turn on condensing unit. In approximately 1 hour cold shots can be dispensed.

CLEANING AND SANITIZING

Your local Health Department rules and general area cleanliness should determine the frequency of which the unit should be sanitized.

SANITIZING PROCEDURES

Your local health department rules and general area cleanliness should determine the frequency at which the unit should be sanitized. Note: Your Liquor plumbing will not need cleaning as often as the Lime mix section of your unit if at all.

EQUIPMENT REQUIRED:

1. Stainless Steel container, (product tank), or large volume container.
2. Cleaning Agent.
3. Sanitizing Solution.
4. Phenolphthalein.

NOTE: One recommended cleaning agent and sanitizing agent is manufactured by:

MT. HOOD CHEMICAL CORP.
4444 N.W. Yeon Avenue
Portland, Oregon 97210

Trade names are: STAR - CHLORINATED CLEANER
CROWN - 12.5% SODIUM HYPOCHLORITE BLEACH

Use STAR at 18 oz. per 1 gallon of water yields 2% Sodium Hydroxide Solution.

Use Crown at 2 ounce per 9 gallons of water (gives 200 PPM of available chlorine) at a minimum contact time of 10 minutes.

1. Turn off the unit at the on/off switch on the rear service panel. Activate the push button switch and empty out product from system by flushing with warm water.
2. Fill bottle reserve with a caustic-based (low sudsing, non-perfumed, and rinsed) detergent solution, (STAR). The solution should be prepared in accordance with the manufacturers recommendations, but should be at least 2 percent sodium hydroxide. Make sure the syrup lines are completely filled and allow standing for at least 10 minutes.
4. Flush the detergent solution from the bottle reserve with clean water. Continue rinsing until testing with phenolphthalein shows that the rinse water is free of residual detergent.
5. Fill the bottle reserve with a low PH (7.0) chloride solution containing maximum 200-PPM chlorine. Make sure that lines are completely filled and allow standing for 30 minutes.
6. Refill bottle reserve with clean hot water.
7. Draw water until chloride solution is dispensed from unit and liquor reservoir is empty.
8. Fill reservoir with Liquor.
9. Push switch until Liquor is dispensed.
10. Wait 45 minutes and then taste the liquor to verify that there is no off taste.

