

# LE MONSTRE

## INSTALLATION AND SERVICE MANUAL

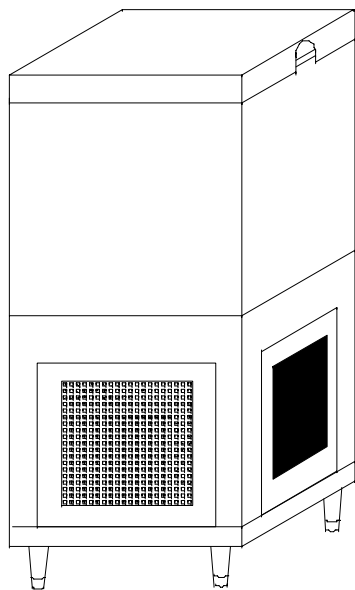

VLM / VLM-3/4  
RC-VLM

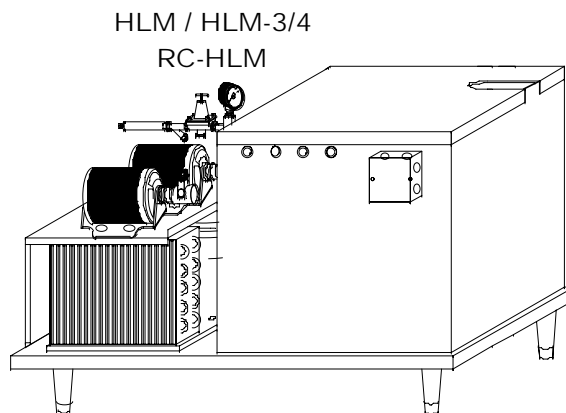

HLM / HLM-3/4  
RC-HLM

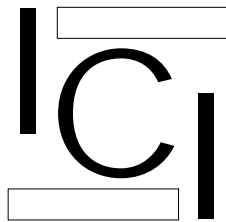

INTERNATIONAL CARBONIC INC.

16630 KOALA RD.

ADELANTO, CA. 92301

IMPORTANT: This manual is a guide for installing, operating, servicing and maintaining this equipment. Refer to Table of Contents for page location of detailed information to answer questions that arise during installation, operating, service and maintenance, or installation of this equipment.

## TABLE OF CONTENTS

	PAGE
PREFACE .....	1
CHAPTER I <u>GENERAL DESCRIPTION</u> .....	2
SYSTEM DESCRIPTION .....	2
DESIGN DATA .....	2
EXPLODED VIEW, VLM .....	4
DESCRIPTION, EXPLODED VIEW, VLM .....	5 - 6
EXPLODED VIEW, HLM .....	7
DESCRIPTION, EXPLODED VIEW, HLM .....	8 - 9
EXPLODED VIEW, RC-VLM .....	10
DESCRIPTION, EXPLODED VIEW, RC-VLM .....	11 - 12
EXPLODED VIEW, RC-HLM .....	13
DESCRIPTION, EXPLODED VIEW, RC-HLM .....	14 - 15
ELECTRICAL SCHEMATIC .....	16
ELECTRICAL SCHEMATIC, S-68-B, DUAL MOTOR .....	17
FLOW CHARTS .....	18
THEORY OF OPERATION .....	19
CHAPTER II <u>INSTALLATION</u> .....	23
UNPACKING AND INSPECTION .....	23
SELECTING LOCATION .....	24
LOCATION RECOMMENDATIONS FOR LE MONSTRE .....	24
INSTALLATION .....	24
INSTALL HIGH PRESSURE CO2 REGULATOR, CO2 CYLINDER AND LINES .....	25
INSTALL LOW PRESSURE REGULATOR AND LINES .....	25
INSTALL WATER FILTER ASSEMBLY, (OPTIONAL) .....	26
INSTALL WATER PRESSURE REGULATOR, (OPTIONAL) .....	26
INSTALL WATER HOLDING TANK, (OPTIONAL) .....	26
INSTALL DRAIN LINE .....	27
INSTALL B.I.B. OR SYRUP TANKS AND ACCESSORIES .....	27
CONNECTING WATER INLET .....	27
ELECTRICAL REQUIREMENTS .....	27
CHAPTER III <u>PREPARATION</u> .....	28
PREPARING SYSTEM FOR OPERATION .....	28
PREPARING AND STARTING REFRIGERATION UNIT .....	28
ACTIVATE HIGH PRESSURE CO2 SYSTEM .....	28
ACTIVATE LOW PRESSURE CO2 GAS AND SYRUP SYSTEMS .....	29
ADJUST WATER FLOW RATE .....	29
ADJUST WATER-TO-SYRUP "RATIO" .....	29
ADJUST SIZE OF DRINK DISPENSED .....	29
CHAPTER IV <u>OPERATORS INSTRUCTIONS</u> .....	30
DAILY PRE-OPERATION CHECK .....	30
REPLENISHING CO2 SUPPLY .....	30
REPLENISHING SYRUP SUPPLY .....	30
COOLING UNIT MAINTENANCE .....	30
CHECKING WATER BATH .....	31
CHANGING WATER BATH .....	31

ADJUSTMENTS.....	31
ADJUSTING WATER FLOW RATE.....	31
ADJUSTING WATER-TO-SYRUP "RATIO" OF DISPENSED PRODUCT .....	31
ADJUSTING SIZE OF DRINK DISPENSED.....	31

TABLE OF CONTENTS (cont'd)	PAGE
TESTING FOR LEAKS .....	31
CHAPTER V SERVICE AND MAINTENANCE.....	33
PERIODIC INSPECTION AND CLEANING.....	33
LE MONSTRE CABINET MAINTENANCE.....	34
CLEANING CONDENSER COIL .....	34
CHECKING/CHANGING WATER BATH.....	34
WATER PUMP MAINTENANCE .....	35
CARBONATOR MAINTENANCE .....	36
LUBRICATION.....	36
SERVICING CHECK VALVES.....	37
EXPLODED VIEW, S-229 ASSEMBLY .....	38
REPLENISHING CO2 SUPPLY.....	39
SYRUP FLAVOR CHANGE.....	39
CHANGING WATER FILTER CARTRIDGE (OPTIONAL) .....	39
ADJUSTMENTS.....	39
HIGH PRESSURE CO2 REGULATOR .....	39
LOW PRESSURE CO2 REGULATOR .....	40
DIET SYRUP TANK CO2 REGULATOR.....	40
CLEANING AND SANITIZING.....	41
CHAPTER VI TROUBLESHOOTING .....	42
CARBONATOR.....	42
WATER PUMP MOTOR WILL NOT OPERATE .....	42
WATER PUMP MOTOR WILL NOT SHUT OFF .....	42
WATER PUMP WILL NOT SHUT OFF AND PRESSURE RELIEF ENGAGED.....	42
SHORT CYCLING OF WATER PUMP MOTOR .....	42
WATER PUMP CAPACITY TOO LOW.....	42
WATER PUMP OPERATES BUT WATER PUMP DOES NOT PUMP .....	42
FROZEN WATER BATH.....	43
COOLING OR CONDENSING UNIT NOT OPERATIONAL.....	43
AGITATOR MOTOR NOT OPERATING .....	43
COMPRESSOR DOES NOT OPERATE .....	43
COMPRESSOR WORKS CONTINUOUSLY BUT DOES NOT FORM SUFFICIENT ICE BANK.....	43
COMPRESSOR WILL NOT STOP AFTER SUFFICIENT ICE BANK IS PRODUCED .....	44
CONDENSER FAN MOTOR NOT OPERATING .....	44
NO SYRUP BEING DISPENSED .....	44
NO WATER BEING DISPENSED.....	44
DISPENSED PRODUCT CARBONATED TO LOW .....	44
DISPENSED PRODUCT MAKES FOAM AS IT LEAVES NOZZLE .....	45
DISPENSED PRODUCT COMES OUT CLEAR BUT FOAMS WHEN IT TOUCHES CUP OR GLASS .....	45
WATER-TO-SYRUP "RATIO" TOO LOW OR TOO HIGH .....	45
ADJUSTMENT OF SYRUP METERING PIN DOES NOT PRODUCE DESIRED WATER-TO-SYRUP "RATIO".....	45
CARBONATION TROUBLESHOOTING FLOW CHART #1 .....	46

CARBONATION TROUBLESHOOTING FLOW CHART #2 .....	47
CARBONATION TROUBLESHOOTING FLOW CHART #3 .....	48
NOTE SECTION .....	49

## PREFACE

INTERNATIONAL CARBONIC INC. has enjoyed over 53 years of manufacturing excellence in the field of carbonation and in the beverage related industry. We have had a long and proud history with quality as our standard and innovation as our goal. Originally started just after World War II in Canfield, Ohio as Carbonic Dispensers. We enjoyed patents on the first Sodajet type carbonator. This method of carbonation instantaneously carbonated the water to 100% saturation. We developed the first patented dispensing valve to dispense bulk beverage with carbonation equal to or in excess of bottled beverages. A valve with three flavors and soda was another first. We were the first to incorporate the total postmix package, i.e., carbonation, refrigeration, and the ability to dispense from one self contained unit. We have pioneered many such firsts and will continue to develop advanced systems for the future, such as electronic interrogatable portion controls to electronic liquid level controls.

We hope you enjoy this piece of equipment that has been produced to give many years of trouble free service. We thank you for your purchase and hope we may serve you in the future.

1  
CHAPTER I

GENERAL DESCRIPTION

This chapter gives the description, theory of operation, and design data for the LE MONSTRE, (VLM, HLM, VLM-3/4, HLM-3/4), and related components.

SYSTEM DESCRIPTION

The LE MONSTRE is a complete self-contained remote cooling/carbonation unit which when combined with related components, will produce a variety of cooled carbonated and non-carbonated beverages.

The LE MONSTRE consists of a condensing unit, a water reservoir, water-cooling coil, a carbonator tank, (carbonated systems only), an agitator pump, and syrup cooling coil(s). The LE MONSTRE is manufactured in two configuration, i.e., Horizontal, (HLM) and Vertical, (VLM).

For proper function the LE MONSTRE must have a water supply, and electrical supply and drainage. Other items that will be required if used in B.I.B., (Bag in Box), or transfer tank, (FIGAL), installations will be high pressure regulator, Low pressure regulator, connecting lines, quick couplers, or disconnects and CO2.

WARNING: Before shipping or relocating a LE MONSTRE into a freezing ambient environment empty plain and carbonated water. Syrup systems should be flushed, ice bank melted, and water drained from water bath. A freezing ambient environment will cause existing water in unit to freeze possibly resulting in damage to pump/motor assembly, syrup coils, water coil, water bath, etc.

TABLE I - I

DESIGN DATA

COOLING UNIT

Overall cabinet dimensions:	VLM	HLM	VLM 3/4	HLM 3/4
Height	42 5/8"	29 1/8"	44 5/8"	29 1/8"
Width	22"	36 3/8"	22"	36 3/8"
Depth	24 1/2"	24 5/8"	24 1/2"	24 5/8"

Weights:

Shipping	243/273	270/303*	271/301*	298/328*
Dry weight	208/238*	230/260*	236/266*	258/288*
Operational Weight	349/379*	371/401*	377/407*	399/429*
Ice Bank	50	50	50	50

\* - Recirculating

Capacities:	Unit water bath (no ice bank)	22.5 gallons
Refrigerant requirement (R-134-A)	HLM/VLM 285 grams HLM/VLM 3/4 331 grams	
Ambient operating temperature		40 F to 100 F.

Electrical Requirements: The cooling unit requires a 115 VAC, single phase, 60 Hertz power circuit.

	VLM/HLM	VLM/HLM 3/4
Circuit Ampacity	16.4/22.6*Amps	17.7/23.9 Amps
Condensing Unit	8.8 Amps	10.1 Amps
Water/Recirc. Pump Motor	6.2 Amps	6.2 Amps
Agitator	1.4 Amps	1.4 Amps

Water Filter Recommended (Optional) See Manufacturer Specifications for Operating Conditions

Incoming Water Pressure Regulator (Optional)	Pressure 25 – 40
C02 High Pressure Regulator (Carbonated units only) PSI	65 – 75
C02 Low Pressure Regulator (Carbonated/Flavored units only)	BIB Approx. 40 PSI
C02 Low Pressure Regulator (Carbonated/Flavored units only)	FIGAL Approx. 30 PSI
C02 Low Pressure Regulator (Optional)	FIGAL Approx. 30 PSI
C02 Diet Drink Pressure Regulator (if required)	6 - 10 PSI
DISPENSING VALVES Ambient Operating Temperature	40 F to 100 F
Electrical Requirements: Operating Voltage	24VAC, 60Hz

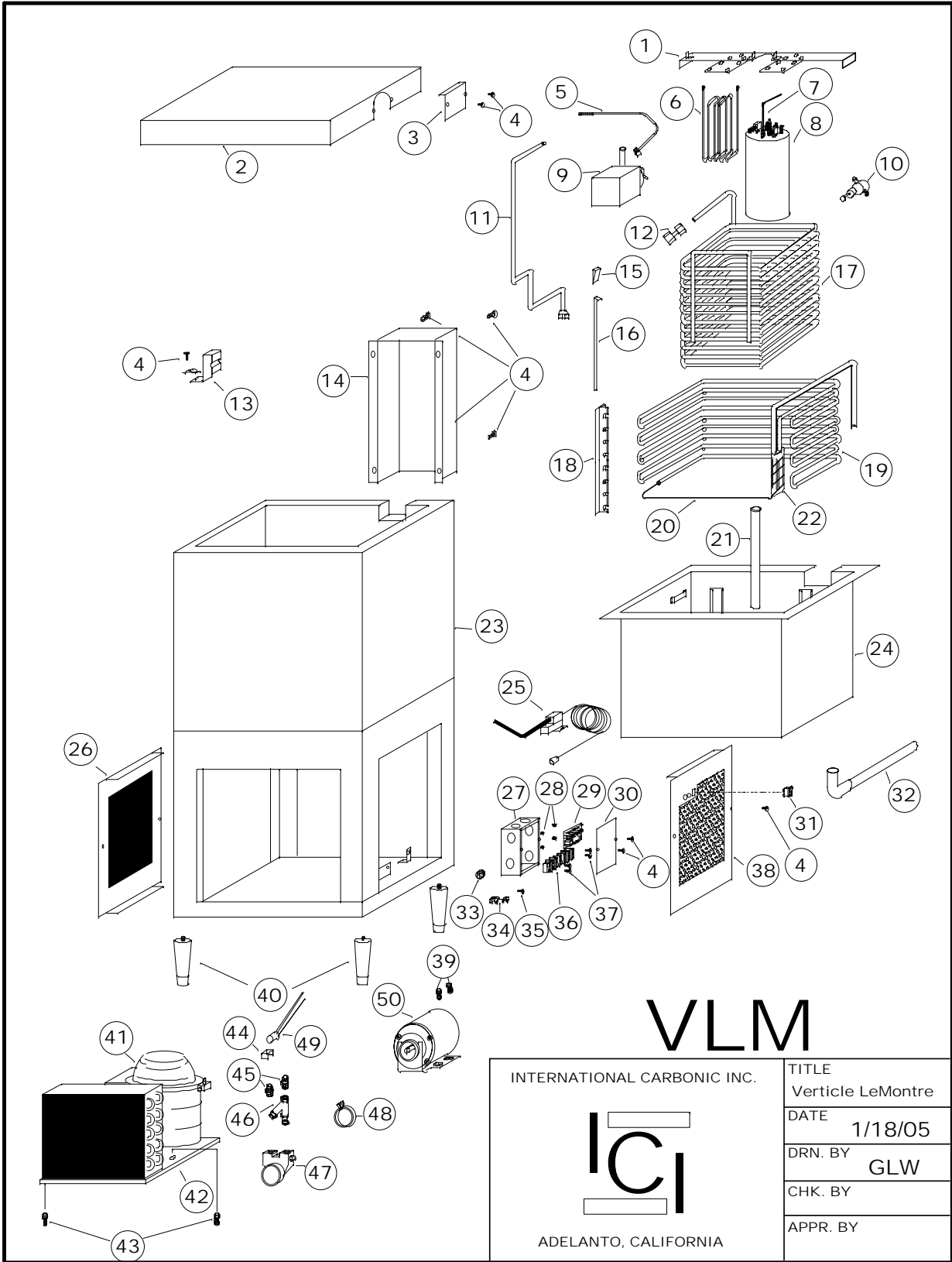

# VLM

INTERNATIONAL CARBONIC INC.



ADELANTO, CALIFORNIA

TITLE	Verticle LeMontre
DATE	1/18/05
DRN. BY	GLW
CHK. BY	
APPR. BY	



FIGURE 1-1

4

# VLM

<b>SYM</b>	<b>QTY</b>	<b>PART NO.</b>	<b>DESCRIPTION</b>
1	1	S0486	CARBONATOR TANK/SYRUP COIL BRACKET
2	1	S0490	LID
3	1	S0474	LID ACCESS PANEL
4	17	A0020	SCREW, 8-32 X 3/8 T.H., S.S.
5	1	G0016	TY-RAP LARGE
6	4 - 8	S0488	SYRUP COIL
7	1	S0072-63	SENSING PROBE ASSEMBLY
8	1	S0265	CARBONATOR TANK ASSEMBLY
9	1	S0850	AGITATOR/CIRCULATOR PUMP
10	1	S0208-A-3/8	WATER REGULATOR
11	1	S0479	WATER LINE, COPPER, PUMP TO COIL
**	1	S0479-3/4	WATER LINE, COPPER, PUMP TO COIL, 3/4 HP
12	1	S0203	UNION
13	1	S1304-U	ICE BANK BULB BRACKET
14	1	S0491	REAR LINE COVER
15	4	S1323	EVAPORATOR GUIDE WEDGE
16	4	S0499	EVAPORATOR COIL RETAINER
17	1	S0495	WATER COIL
18	4	S0498	EVAPORATOR SUPPORT BRACKET
19	1	S0497	EVAPORATOR ASSEMBLY
**	1	S0497-3/4	EVAPORATOR ASSEMBLY, 3/4 HP
20	1	Z0008	1/8 CAP TUBE, 10.5
**	1	Z0008	1/8 CAP TUBE, 14'
21	1	S0487	STANDPIPE
22	1	S0409	9" ACCUMULATOR
23	1	S0493	CABINET SHELL ONLY, VLM
**	1	S0493-3/4	CABINET SHELL ONLY, VLM, 3/4 HP
24	1	S0496	BUCKET COMPLETE

FIGURE 1-2

5

# VLM Cont.

<b>SYM</b>	<b>QTY</b>	<b>PART NO.</b>	<b>DESCRIPTION</b>
25	1	S0513-A	ICE BANK CONTROL
26	2	S0492	SERVICE PANEL, LEFT AND FRONT
**	2	S0492-3/4	SERVICE PANEL, LEFT AND FRONT
27	1	S1308	CONTROL BOX W/COVER
28	4	S1335	TERMINAL BOARD SPACER, NYLON, 3/8"
29	1	S0068-B	LIQUID LEVEL CONTROL
30	1	S1310	CONTROL BOX COVER
31	1	S0783	ROCKER SWITCH
32	1	S0489	WATER BATH DRAIN
33	8	S0046	BUSHING
34	1	E0664	STRAIN RELIEF
35	1	A0067	8-32 X 3/8 HEX HD, PH GREEN GROUND SCREW
36	1	S1815	TERMINAL BLOCK, DIRECT WIRE
37	4	A0021	SCREW, 8-32 X 1/2 T.H., S.S.
38	1	S0468	SERVICE PANEL, RIGHT
**	1	S0468-3/4	SERVICE PANEL, RIGHT
39	2	A0045	5/16 X 18 FLANGE WHIZ LOCK SCREW, 1/2"
40	1 SET	S0854	LEGS, SS
41	1	AKA4476YXA	COMPRESSOR ONLY
**	1	AJA7461YXA	COMPRESSOR ONLY, 3/4 HP
42	1	AKA7437YXAXA	1/2 H.P. CONDENSING UNIT
**	1	AJA7465YXAXG	3/4 H.P. CONDENSING UNIT
43	2	A0046	5/16 X 18 FLANGE WHIZ LOCK SCREW, 3/4"
44	1	S0104	PUMP PROTECTOR BRACKET
45	2	S0170	HALF UNION, BRASS
46	1	S0650	STRAINER, BRASS
47	1	S0200	CARBONATOR PUMP
48	1	S0106	CLAMP
49	1	S0103	PUMP PROTECTOR

50	1	S0096	MOTOR
** - Denotes 3/4 horse power components.			

FIGURE 1-2 Cont  
6

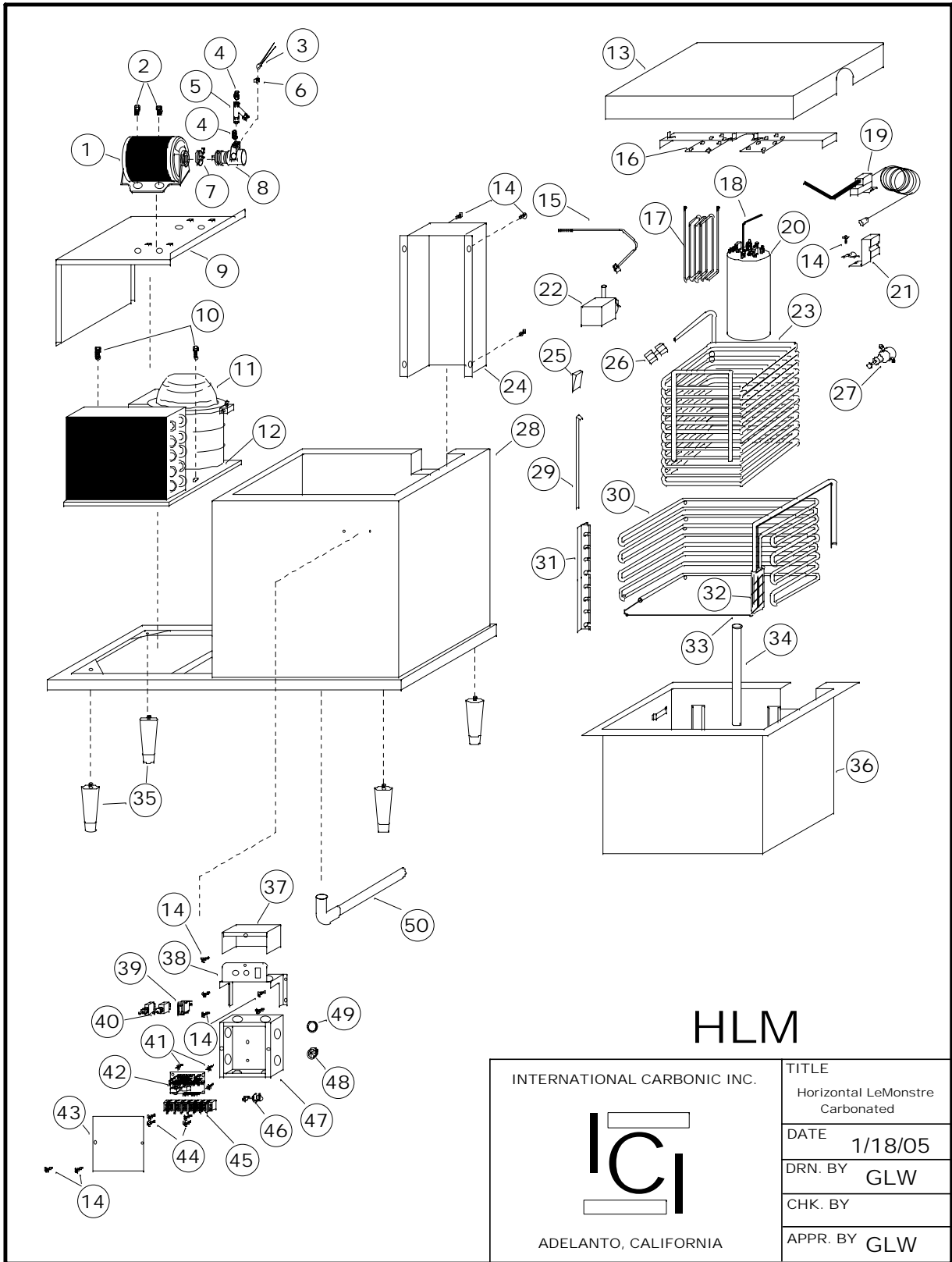

# HLM

INTERNATIONAL CARBONIC INC.	TITLE Horizontal LeMonstre Carbonated
 ADELANTO, CALIFORNIA	DATE 1/18/05
	DRN. BY GLW
	CHK. BY
	APPR. BY GLW

FIGURE 1-3  
7

# HLM

SYM	QTY	PART NO.	DESCRIPTION
1	1	S0096	MOTOR
2	2	A0045	5/16 X 18 FLANGE WHIZ LOCK SCREW, 1/2"
3	1	S0103	PUMP PROTECTOR
4	2	S0594	HALF UNION, BRASS
5	1	S0650	STRAINER, BRASS
6	1	S0104	PUMP PROTECTOR BRACKET
7	1	S0106	CLAMP
8	1	S0200	CARBONATOR PUMP
9	1	S0466	MOTOR MOUNTING PANEL
**	1	S0466-3/4	MOTOR MOUNTING PANEL, 3/4 HP
10	2	A0046	5/16 X 18 FLANGE WHIZ LOCK SCREW, 3/4"
11	1	AKA4476YXA	COMPRESSOR ONLY
**	1	AJA7461YXA	COMPRESSOR ONLY, 3/4 HP
12	1	AKA7437YXAXA	1/2 H.P. CONDENSING UNIT
**	1	AJA7465YXAXG	3/4 H.P. CONDENSING UNIT
13	1	S0490	LID
14	14	A0020	SCREW, 8-32 X 3/8 T.H., S.S.
15	1	G0016	TY-RAP LARGE
16	1	S0486	CARBONATOR TANK/SYRUP COIL BRACKET
17	4 - 8	S0488	SYRUP COIL
18	1	S0072-63	SENSING PROBE ASSEMBLY
19	1	S0513-A	ICE BANK CONTROL
20	1	S0265	CARBONATOR TANK ASSEMBLY
21	1	S1304-U	ICE BANK BULB BRACKET
22	1	S0850	AGITATOR/CIRCULATOR PUMP
23	1	S0495	WATER COIL
24	1	S0491	REAR LINE COVER
25	4	S1323	EVAPORATOR GUIDE WEDGE

FIGURE 1-4

# HLM Cont.

SYM	QTY	PART NO.	DESCRIPTION
26	1	S0203	UNION
27	1	S0208-A-3/8	WATER REGULATOR
28	1	S0465	CABINET SHELL ONLY, HLM
29	4	S0499	EVAPORATOR COIL RETAINER
30	1	S0497-H	EVAPORATOR ASSEMBLY, HORIZONTAL
**	1	S0497-H-3/4	EVAPORATOR ASSEMBLY, HORIZONTAL, 3/4 HP
31	4	S0498	EVAPORATOR SUPPORT BRACKET
32	1	S0409	9" ACCUMULATOR
33	1	Z0008	1/8 CAP TUBE, 10.5'
**	1	Z0008	1/8 CAP TUBE, 14'
34	1	S0487	STANDPIPE
35	1 SET	S0854	LEGS
36	1	S0496	BUCKET COMPLETE
37	1	S0464	SWITCH PANEL COVER ONLY
38	1	S0467	SWITCH PANEL
39	1	S0783	ROCKER SWITCH
40	2	S0866	TOGGLE SWITCH
41	4	S1335	TERMINAL BOARD SPACER, NYLON, 3/8"
42	1	S0068-B	LIQUID LEVEL CONTROL
43	1	S1310	CONTROL BOX COVER
44	4	A0021	SCREW, 8-32 X 1/2 T.H., S.S.
45	1	S1815	TERMINAL BLOCK, DIRECT WIRE
46	1	E0664	STRAIN RELIEF
47	1	S1308	CONTROL BOX W/COVER
48	4	S0046	BUSHING
49	10	S-7/8	HOLE PLUG
50	1	S0489	WATER BATH DRAIN

\*\* - Denotes 3/4 horse power components.

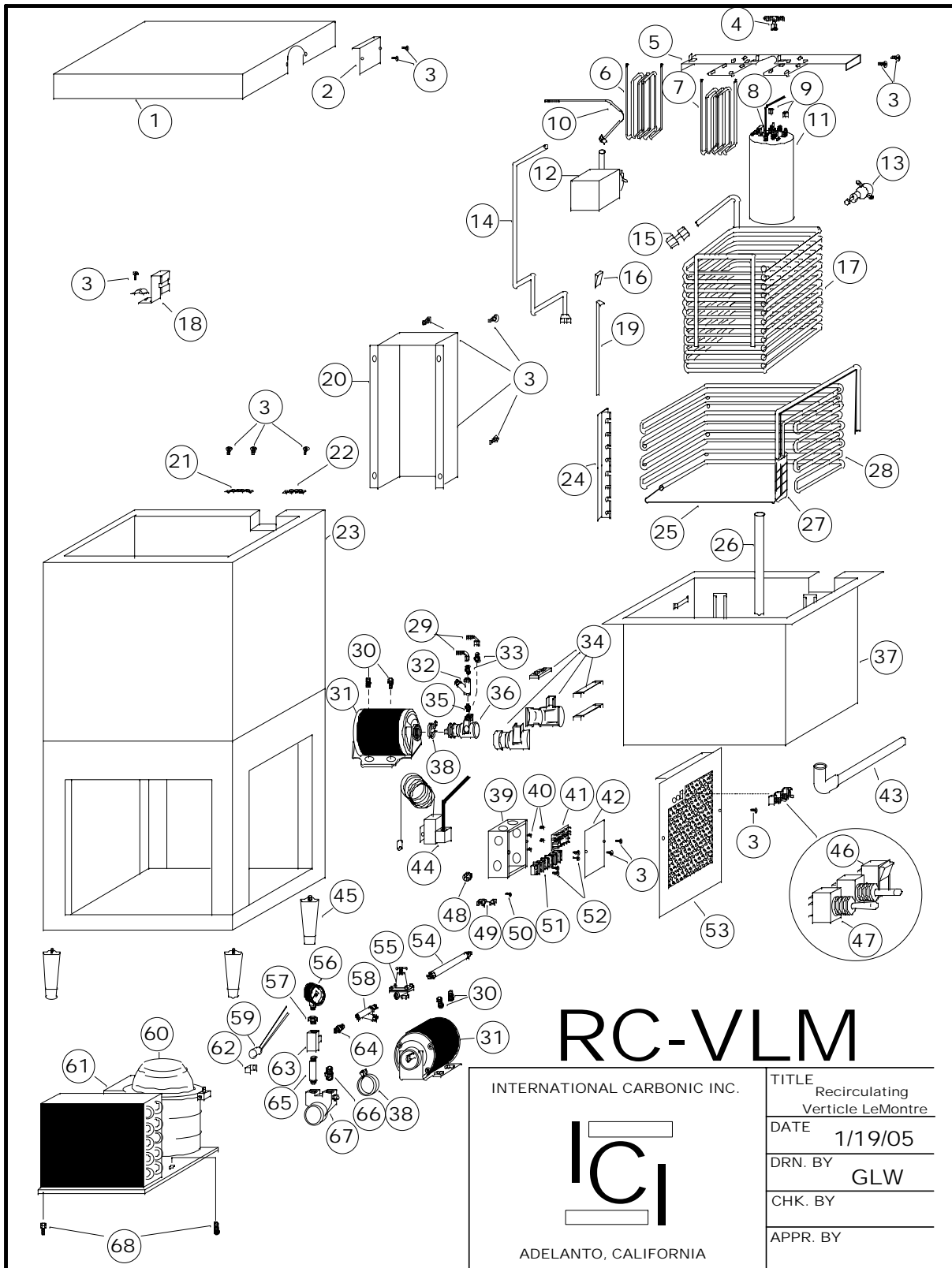

# RC-VLM

INTERNATIONAL CARBONIC INC.



ADELANTO, CALIFORNIA

TITLE	Recirculating Venticle LeMontre
DATE	1/19/05
DRN. BY	GLW
CHK. BY	
APPR. BY	

FIGURE 1-5  
10

# RC-VLM

SYM	QTY	PART NO.	DESCRIPTION
1	1	S0490	LID ASSEMBLY
2	1	S0474	LID ASSEMBLY
3	21	A0020	SCREW, 8-32 X 3/8 T.H., S.S.
4	1	S0555	TEE, SWIVEL HOSE, S.S., 5/16H X 5/16H X 1/4FF
5	1	S0486	CARBONATOR TANK/SYRUP COIL BRACKET
6	4 - 8	S-488	SYRUP COIL
7	2	S0488-P	POST/PRE-COOLING COIL
8	1	S0072-63	PROBE ASSEMBLY
9	2	S0059	CAP, S.S., 1/4 F. FL.
10	1	G0016	PUMP BRACKET CLIP
11	1	S0265	CARBONATOR TANK ASSEMBLY
12	1	S0850	AGITATOR/CIRCULATOR PUMP
13	1	S0208-A-3/8	WATER REGULATOR
14	1	S0479	WATER LINE, COPPER, PUMP TO COIL
**	1	S0479-3/4	WATER LINE, COPPER, PUMP TO COIL, 3/4 H.P.
15	1	S0203	UNION
16	4	S1323	EVAPORATOR GUIDE WEDGE
17	1	S0495	WATER COIL
18	1	S1304-U	ICE BANK BULB BRACKET
19	4	S0499	EVAPORATOR COIL RETAINER
20	1	S0491	REAR LINE COVER
21	0-2	S0387	GANG STRAP 4 WAY, 1/4" TUBING
22	0-2	S0386	GANG STRAP 3 WAY, 1/4" TUBING
23	1	S0493	CABINET SHELL ONLY, VLM
24	4	S0498	EVAPORATOR COIL SUPPORT BRACKET
25	1	.....	1/8 CAP TUBE, 10.5, (1/2 HP)
**	1	.....	1/8 CAP TUBE, 14', (3/4 HP)
26	1	S0487	STANDPIPE, 15"
27	1	S0409	9" ACCUMULATOR
28	1	S0497	EVAPORATOR ASSEMBLY, 1/2 HP
**	1	S0497-3/4	EVAPORATOR ASSEMBLY, 3/4 HP
29	2	S0533	SWIVEL ELBOW, 90 DEGREE, 1/4" FF X 5/16" H., SS
30	4	A0045	5/16 X 18 1/2" FLANGE WHIZ LOCK SCREW
31	2	S0096	MOTOR
32	1	S0651	STRAINER, PLASTIC
33	2	S0592	HALF UNION, S.S., 3/8 MP X 1/4 MF
34	1 SET	S0665	PUMP INSULATION KIT
35	1	S0640	NIPPLE, 3/8 MP, S.S., HEX
36	1	S0400	CARBONATOR PUMP, S.S., 100 GPH

FIGURE 1-6



# RC-VLM Cont.

SYM	QTY	PART NO.	DESCRIPTION
37	1	S0496	BUCKET COMPLETE
38	2	S0106	CLAMP, "V" BAND CLAMP
39	1	S1308	CONTROL/TERMINAL BOX W/COVER
40	4	S1335	TERMINAL BOARD SPACER, NYLON, 3/8"
41	1	S0068-B	LIQUID LEVEL CONTROL
42	1	S1310	CONTROL/TERMINAL BOX COVER
43	1	S0489	WATER BATH DRAIN
44	1	S0513-A	ICE BANK CONTR0L
45	1 SET	S0854	LEGS, S.S., 6"
46	1	S0783	ROCKER SWITCH
47	1 - 2	S0866	TOGGLE SWITCH
48	8	S0046	BUSHING
49	2	E0664	STRAIN RELIEF
50	1	A0067	8-32 X 3/8 HEX HD, PH GREEN GROUND SCREW
51	1	S1815	TERMINAL BLOCK, DIRECT WIRE
52	4	A0021	SCREW, 8-32 X 1/2 T.H., S.S.
53	1	S0468	SERVICE PANEL, RIGHT
**	1	S0468-3/4	SERVICE PANEL, 3/4 HP, RIGHT, NOT SHOWN
.....	2	S0492	SERVICE PANEL, LEFT & FRONT, NOT SHOWN
**	2	S0492-3/4	SERVICE PANEL, 3/4 HP, LEFT & FRONT, NOT SHOWN
54	1	S0208-A-3/8	REGULATOR, WATER PRESSURE
55	1	S0572	HOSE ASSY., PUMP INLET, 6" (3/8" INNERBRAID)
56	1	S0110	0-60 GAUGE, 1/4 NPT
57	1	I0006	BUSHING, BRASS, 3/8"MP X 1/4" FP
58	1	S0650	"Y" STRAINER, BRASS
59	1	S0103	PUMP PROTECTOR
60	1	AKA4476YXA	COMPRESSOR ONLY, 1/2 HP
**	1	AJA7461YXA	COMPRESSOR ONLY, 3/4 HP
61	1	AKA7437YXAXA	1/2 H.P. CONDENSING UNIT
**	1	AJA7465YXAXG	3/4 H.P. CONDENSING UNIT
62	1	S-104	PUMP PROTECTOR BRACKET
63	1	S-171	TEE, BRASS, 3/8" F.P.
64	1	S-181	NIPPLE, BRASS, 3/8" X 3/8" PIPE (HEX NIPPLE)
65	1	S-174	NIPPLE, BRASS, 3/8" M.P. X 3"
66	1	S-170	HALF UNION, BRASS, 3/8 MP X 3/8 MF
67	1	S-200	CARBONATOR PUMP, 100 GPH
68	2	A0046	5/16 X 18 FLANGE WHIZ LOCK SCREW, 3/4"

\*\* - Denotes 3/4 horse power components.

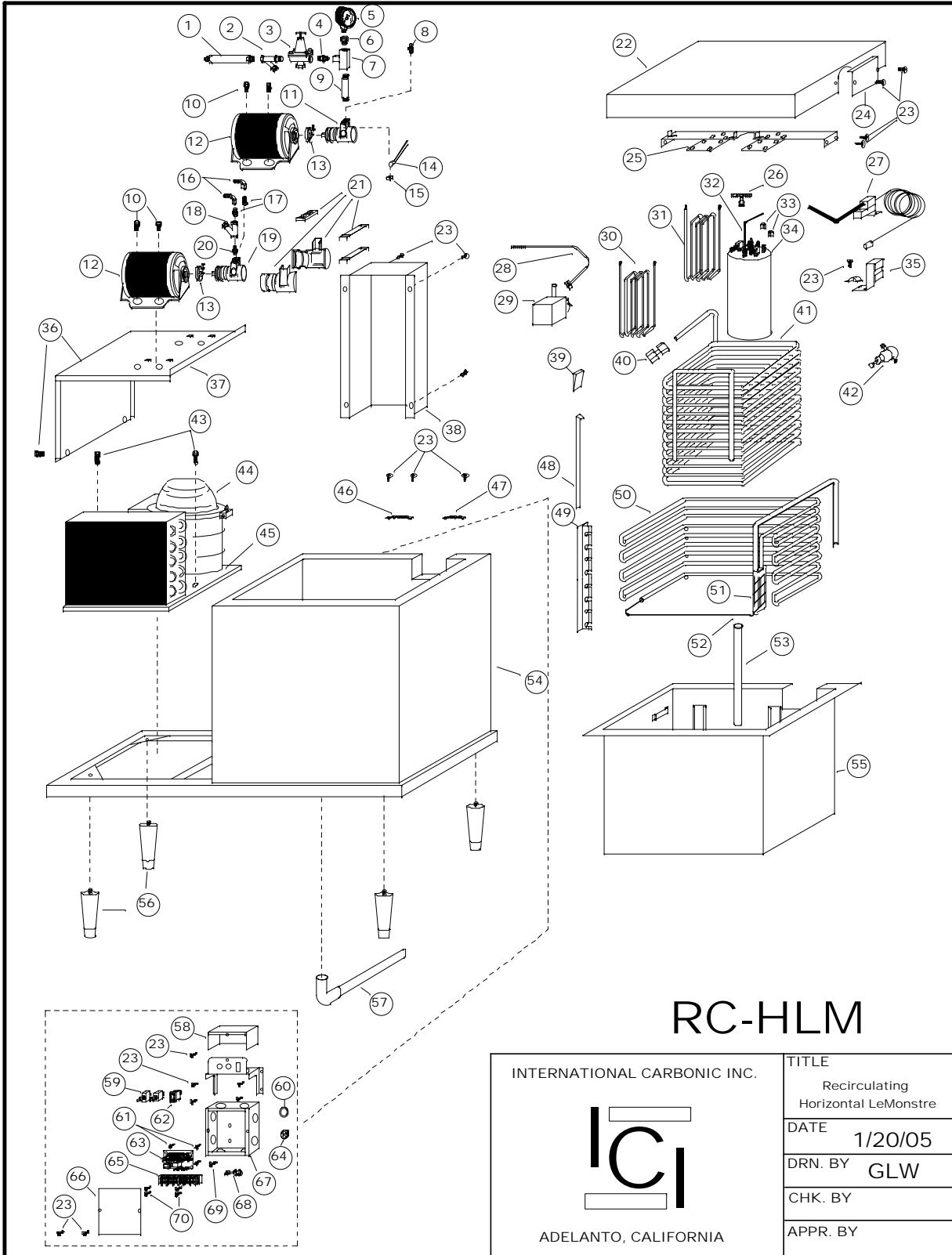

# RC-HLM

INTERNATIONAL CARBONIC INC.  ADELANTO, CALIFORNIA	TITLE Recirculating Horizontal LeMonstre
	DATE 1/20/05
	DRN. BY GLW
	CHK. BY
	APPR. BY

FIGURE 1-7  
13

# RC-HLM

SYM	QTY	PART NO.	DESCRIPTION
1	1	S-572	HOSE ASSY., PUMP INLET, 6" (3/8" INNERBRAID)
2	1	S-650	"Y" STRAINER, BRASS
3	1	S-208	REGULATOR, WATER PRESSURE
4	1	S-181	NIPPLE, BRASS, 3/8" X 3/8" PIPE (HEX NIPPLE)
5	1	S-110	0-60 GAUGE, 1/4 NPT
6	1	I0006	BUSHING, BRASS, 3/8"MP X 1/4" FP
7	1	S-171	TEE, BRASS, 3/8" F.P.
8	1	S-170	HALF UNION, BRASS, 3/8 MP X 3/8 MF
9	1	S-174	NIPPLE, BRASS, 3/8" M.P. X 3"
10	4	A-45	5/16-18 X 1/2" FLANGE WHIZ LOCK SCREW
11	1	S-200	CARBONATOR PUMP, 100 GPH
12	2	S-96	MOTOR
13	2	S-106	CLAMP, "V" BAND CLAMP
14	1	S-103	PUMP PROTECTOR
15	1	S-104	PUMP PROTECTOR BRACKET
16	2	S-533	SWIVEL ELBOW, 90 DEGREE, 1/4" FF X 5/16" H., SS
17	2	S-592	HALF UNION, S.S., 3/8 MP X 1/4 MF
18	1	S-651	STRAINER, PLASTIC
19	1	S-400	CARBONATOR PUMP, S.S., 100 GPH
20	1	S-640	NIPPLE, 3/8 MP, S.S., HEX
21	1 SET	S-665	PUMP INSULATION KIT
22	1	S-490	LID ASSEMBLY
23	17	A-20	SCREW, 8-32 X 3/8 T.H., S.S.
24	1	S-486	CARBONATOR TANK/SYRUP COIL BRACKET
25	1	S-555	TEE, SWIVEL HOSE, S.S., 5/16H X 5/16H X 1/4FF
26	1	S-513-A	ICE BANK CONTROL
27	1	S-485-LG	PUMP BRACKET CLIP
28	1	S-850	AGITATOR/CIRCULATOR PUMP
29	2	S-488-P	POST/PRE-COOLING COIL
30	4 - 8	S-488	SYRUP COIL
31	1	S-72-63	PROBE ASSEMBLY
32	2	S-59	CAB, S.S., 1/4" F. FL
33	1	S-265	CARBONATOR TANK ASSEMBLY
34	2	A-52	6-32 X 3/8 PH
35	1	S-1304-A	ICE BANK CONTROL BRACKET
36	2	S-59	1/4-20 X 1/2" HH CAP SCREW
37	1	S-466	MOTOR MOUNTING PANEL

FIGURE 1-8

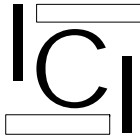
# RC-HLM Cont.

SYM	QTY	PART NO.	DESCRIPTION
**	1	S-466-3/4	MOTOR MOUNTING PANEL, 3/4 HP
38	1	S-491	REAR LINE COVER
39	4	S-1323	EVAPORATOR GUIDE WEDGE
40	1	S-203	UNION
41	1	S-495	WATER COIL
42	1	S-208-A-3/8	WATER REGULATOR
43	2	A-46	5/16 X 18 FLANGE WHIZ LOCK SCREW, 3/4"
44	1	AKA4476YXA	COMPRESSOR ONLY, 1/2 HP
**	1	AJA7461YXA	COMPRESSOR ONLY, 3/4 HP
45	1	AKA7437YXAXA	1/2 H.P. CONDENSING UNIT
**	1	AJA7465YXAXG	3/4 H.P. CONDENSING UNIT
46	0-2	S-387	GANG STRAP, 4 WAY, 1/4" TUBING
47	0-2	S-386	GANG STRAP, 3 WAY, 1/4" TUBING
48	4	S-499	EVAPORATOR COIL RETAINER
49	4	S-498	EVAPORATOR COIL SUPPORT BRACKET
50	1	S-497-H	EVAPORATOR ASSEMBLY, HORIZONTAL, 1/2 HP
**	1	S-497-H-3/4	EVAPORATOR ASSEMBLY, HORIZONTAL, 3/4 HP
51	1	S-409	9" ACCUMULATOR
52	1	.....	1/8 CAP TUBE, 10.5, (1/2 HP)
**	1	.....	1/8 CAP TUBE, 14', (3/4 HP)
53	1	S-487	STANDPIPE, 15"
54	1	S-465	CABINET SHELL ONLY, HLM
55	1	S-496	BUCKET COMPLETE
56	1 SET	S-854	LEGS, S.S., 6"
57	1	S-489	WATER BATH DRAIN
58	1	S-866	TOGGLE SWITCH
59	2	E-664	STRAIN RELIEF
60	6	S-7/8	HOLE PLUG
61	4	S-1335	TERMINAL BOARD SPACER, NYLON, 3/8"
62	2	A-49	8-32 X 3/8 PH TYPE F SELF TAP
63	6	S-46	BUSHING
64	1	S-1308	CONTROL/TERMINAL BOX W/COVER
65	1	S-68-B	LIQUID LEVEL CONTROL
66	1	S-1310	CONTROL/TERMINAL BOX COVER
67	1	A-67	8-32 X 3/8 HEX HD GREEN GROUND SCREW
68	2	E-141-9	CORD
** - Denotes 3/4 horse power components.			

FIGURE 1-8 Cont.

# DUAL CARB DIRECT WIRE

"USE COPPER CONDUCTOR WIRE ONLY"

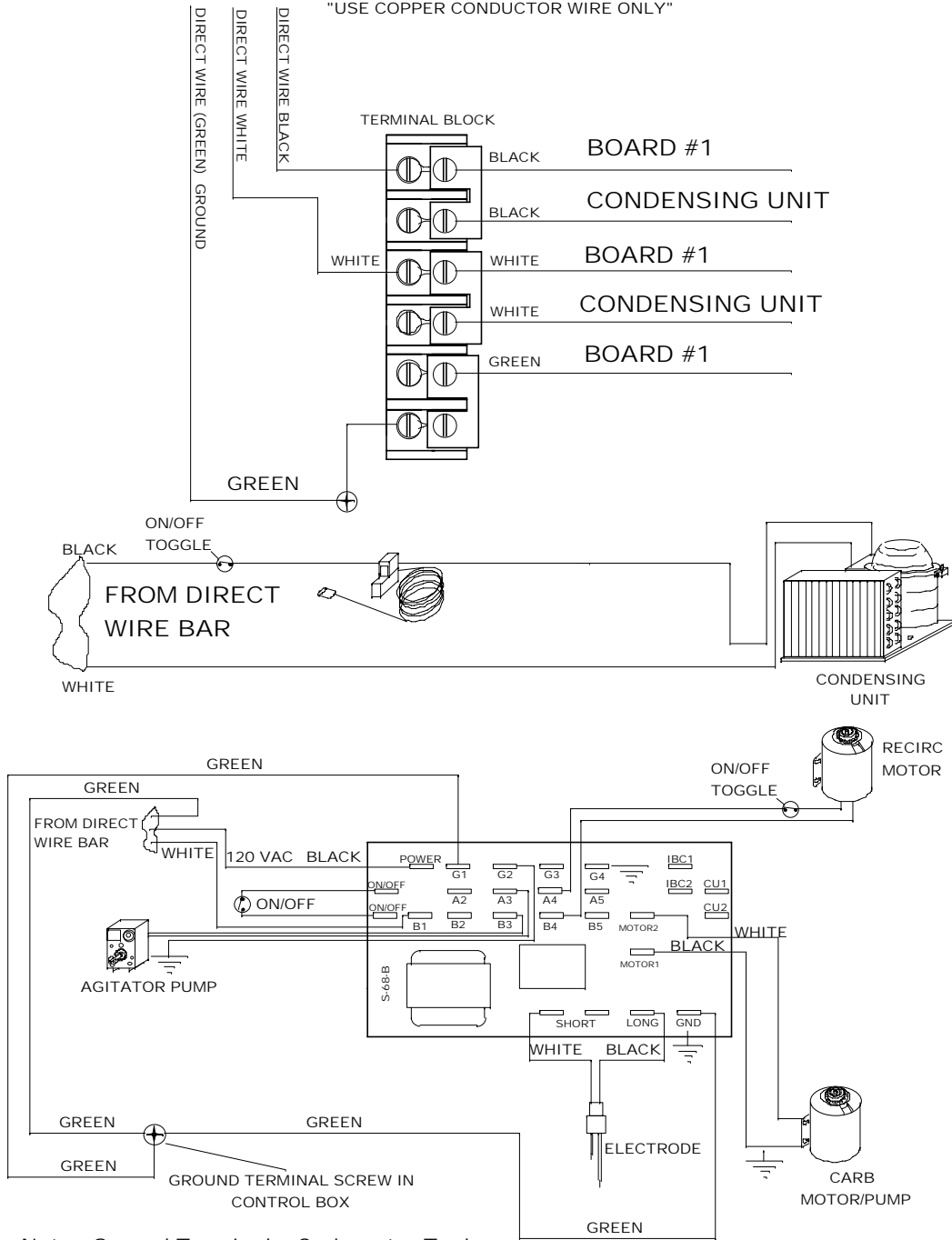

Note: Ground Terminals, Carbonator Tank  
and Water Bath must be  
Commonly Grounded

FIGURE 1-9  
16

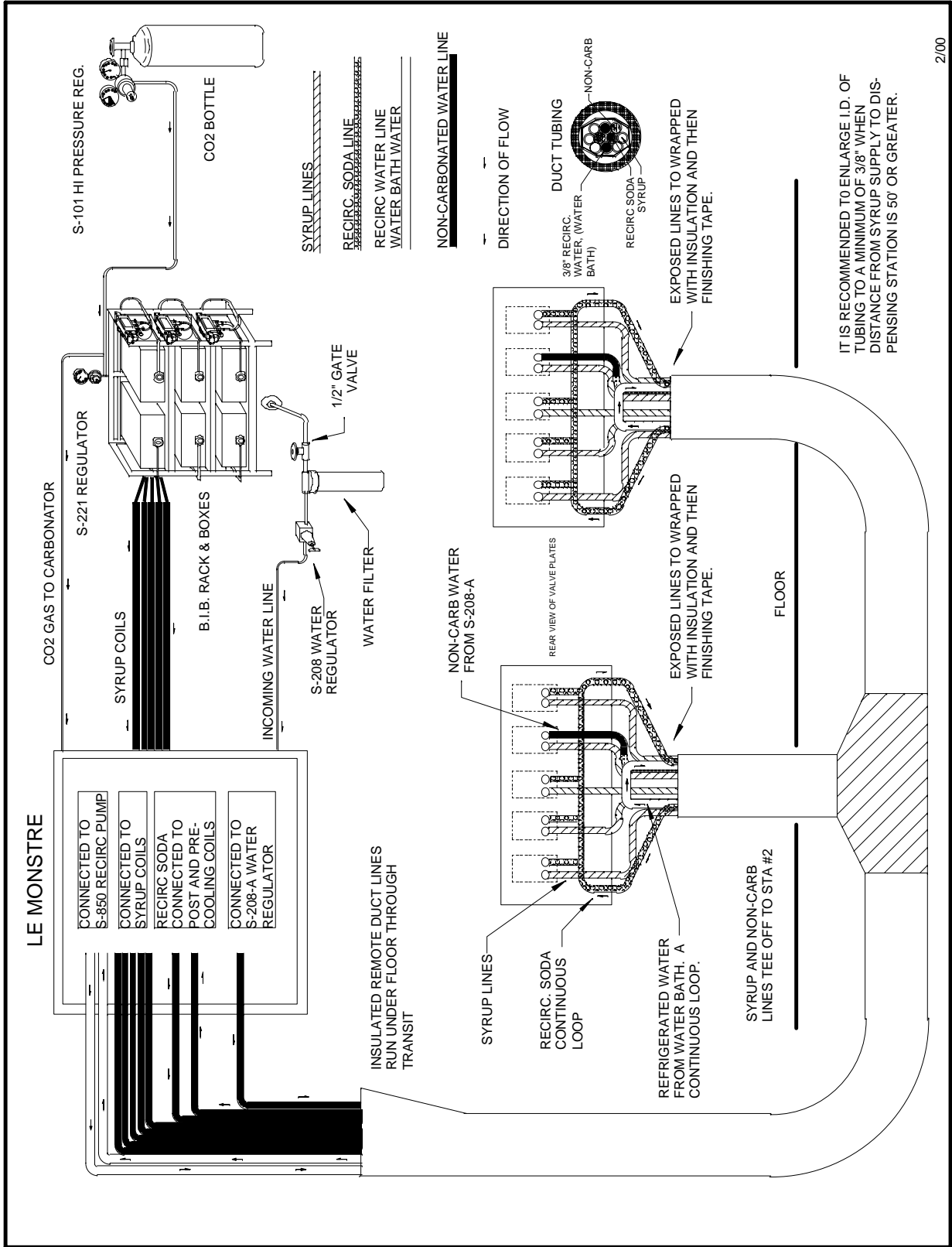

FIGURE 1-10  
 17

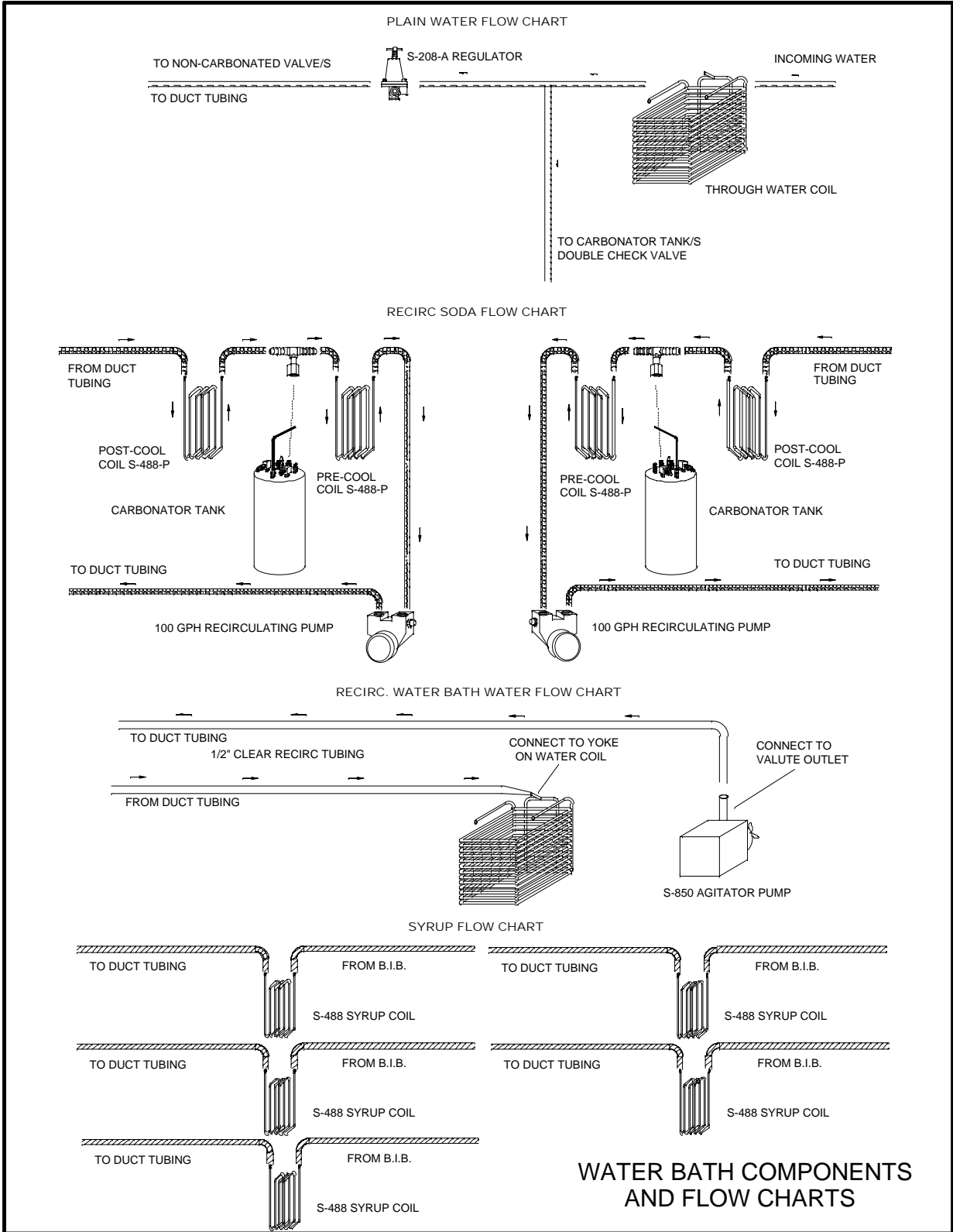

FIGURE 1-11  
18

## THEORY OF OPERATION

The LE MONSTRE was designed to manufacture and dispense carbonated or non-carbonated beverages much like your local bottling plant that cans or bottles your favorite carbonated or non-carbonated drink.

Initially water is chilled and then carbonated to dispense a quality drink. To chill the water the water is routed through a water coil that is submerged in an ice cold water bath. The temperature of the incoming water is at ambient temperature as it enters the water coil. As the incoming water passes through the water coil the heat is removed from the water in the water coil and chilled to a temperature acceptable for a quality drink. In both cases, carbonated or juice drinks, this procedure is performed. If the LE MONSTRE is a carbonated unit the water is now routed into a carbonator tank where this cold water is mixed with CO<sub>2</sub>. This water is now transformed into a carbonic acid, (soda water), and then routed to a valve where it will be mixed with a syrup concentrate and dispensed. In the case of the juice or non-carbonated drinks the carbonator tank is not needed so the chilled water is directed straight to the valve. Again it is mixed with a syrup concentrate and then dispensed.

The water bath holds approximately 22.5 gallons of water. A certain amount of this water will be transformed into ice, approximately 50 pounds. This water reserve and ice bank will act as a reservoir for refrigeration. This reserve is utilized during peak periods when the BTU output of the compressor is not sufficient to meet the demand of the draw.

It should be recognized that without refrigeration your carbonation system would not produce a drink that will hold carbonation. There is a direct relationship between dispensed temperature and the volumes of CO<sub>2</sub> that can be held in liquid form.

The following will give a general overview of the flow of individual circuits and a clearer understanding of our mini bottling plant.

Carbon dioxide gas (CO<sub>2</sub>) passes from a CO<sub>2</sub> cylinder through high-pressure regulator (S-101). The high-pressure regulator regulates the CO<sub>2</sub> feeding the LE MONSTRE and should be set at 70-75 PSI. The gas, after leaving the high-pressure regulator, is routed through flexible tubing to a low-pressure regulator. The flow of CO<sub>2</sub> is teed to go in two directions at the low-pressure regulator. One path takes the gas, set at 65 to 75 PSI, to the carbonator tank. This gas must be at a pressure greater than the incoming water by at least 25-PSI to assure the proper function of the carbonator. The second path of CO<sub>2</sub> is routed through low-pressure regulator to be regulated at pressures suitable for the syrup concentrate being dispensed. The low-pressure regulator may be set at many different settings but primarily the settings are directed towards B.I.B. or transfer tank type installations. The average settings may vary from 10 to 60 PSI, this of course will be influenced by length of run, ambient temperature and baume of product. Typically B.I.B. installations are set at an average of 40 PSI and transfer tank installations are set at an average of 30 PSI.

As discussed earlier plain water enters the LE MONSTRE through the incoming water line. This water proceeds through the water coil where it is chilled prior to entering the carbonator tank or in the case of non-carbonated drinks chilled prior to going directly to a valve. Prior to entering the carbonator tank an optional regulator (S-208A) may be installed. This assembly is utilized to maintain water pressure feeding a non-carbonated valve when used in conjunction with a carbonated valve.



The water source should be regulated, this is normally performed by the use of an in line water regulator. If the water is not regulated and the water pressure is equal or greater than the incoming CO<sub>2</sub> the act of carbonation will be greatly inhibited or completely eliminated.

At the proper settings, the gas pressure will stop the water from entering the carbonator tank. To force the water into the tank a liquid level control and motor/pump will be used. This combination will force the water into the tank mixing the water and CO<sub>2</sub> together.

The carbonator utilizes a Soda Jet Recirculating Principle. Our Company pioneered this principle in the early 1950's. This principle produces instantaneous carbonation at extremely large capacities of 100 gallons per hour minimum.

The level of the carbonated waters within the stainless steel mixing tank, (carbonator tank), will determine the cycle on or cycle off of the water pump and motor. The liquid level control, in conjunction with a probe housed in the carbonator tank, control the pump motor. The motor will come on when the carbonated water within the mixing tank recedes to a predetermined low level and stops the pump motor when the carbonated water reaches a predetermined high level.

During the cycle of operation, fresh water enters the carbonator tank through the soda jet after passing through a short tube to the water pump inlet fittings. The water pump has impellers which drives the water through a dual check valve and then through the soda jet and into the carbonator tank.

The position and angle of the soda jet is fixed to direct an extremely high velocity solid jet of fresh water so as to impinge upon the surface of the stored body of carbonator water within the stainless steel mixing tank. The force created by this jet of fresh water entering the mixing tank causes all the water within to cascade and foamesce through the carbon dioxide gas area in a continuous recirculating-manner.

This action causes a breakdown of the surface tension of the water, forming numerous minute gases filled water bubbles. The micro thin walls of these water bubbles surrounded by gas both inside and out, offer maximum water surface for the absorption of the gas. The size opening through this jet permits large volumes of water to be carbonated.

As the incoming water is being carbonated, the level within the tank rises to contact the upper probe, which will de-energize a relay on the liquid level control and stop the motor from turning the pump. This motor will be inactive until water within the tank recedes below the long probe, at which time, the relay on the liquid level control will close, engaging the motor once again.

#### REMOTE CIRCULATING COOLING SYSTEM

The remote station circulating cooling system is used as its name implies to cool the water, soda water, and syrup lines between the dispenser and the remote stations.

The cooling is accomplished by circulating the water from the cold water bath of the dispenser through tubing to the remote station and then returning this partially warmed water to the water bath.

When installing stations remote from the dispenser cabinet, the following operations are very important:

Location of the Cabinet: - Locating the dispenser cabinet properly depends upon two factors: convenience to the user and convenience of installation and service.

If cabinet is not used as a serving station it is permissible to place it in a basement, back room, or any other out of the way place. However, it is important to locate the cabinet as close as possible to the remote station in order to keep the heat loss through the insulated extended lines at a minimum. When used as a serving station, it is necessary to place the cabinet where it will be most accessible to the operator.

Water shut off valves and power switches should be located as near the cabinet as possible in order to facilitate service. Where an air-cooled condenser is used, there should be enough space surrounding the cabinet to insure adequate air circulating through the refrigeration condenser. Space should also be provided if possible, for doing service work on the cabinet. Note: when units are located in isolated rooms outside ventilation is necessary and air conditioning is recommended.

**CAUTION:** In order to have even distribution of cold water, the cold water circulating lines must always be run in series even on multiple station installations.

**IMPORTANT:** Be sure to leave all connections and fittings exposed until after the entire system has been pressure tested.

In order to insure maximum heat transfer between the braided plastic lines (through which the water, soda, and syrup are carried) and the circulating tubing, it is necessary to tape these lines firmly together.

When the remote lines consist of three syrup lines and one soda line, tape the soda line and one syrup line to the inside of the out-going water circulating tubing and tape the remaining two syrup lines to the inside of the return water circulating tubing.

When there is a fresh water remote line used, then the fresh water line and the soda line are taped to the inside of the out-going water circulating tubing and the three syrup lines taped to the inside of the return water circulating tubing. The lines should be taped at one-foot intervals.

The two groups of lines should then be drawn together and taped firmly so that the braided lines are on the inside of the cluster.

It is of utmost importance that the extended lines of the remote installation be properly and adequately insulated. Failure to do this will cause overloading of the refrigeration unit and ice bank, condensation on the outside of the insulation and reduced cold drink dispensing capacity.

**CAUTION:** All open ends, joints and connections of the insulation must be sealed air tight to prevent outside air from entering the insulated duct. Outside air, which contains moisture would condense this moisture within the insulation duct resulting in the insulation becoming wet, which would reduce its insulating qualities. Water dripping from duct would also result.

Pressure Drop within the Carbonated Water Lines – All Soda systems will maintain the pressure necessary to prevent any carbonation loss through out the entire system even while the valve is open.

Attention must be given to avoid restrictions in the lines, which may cause a reduction in pressure upon the carbonated water and allow some of the gas to escape from the carbonated water in the lines.

The pressure is measured on pounds per square inch and is the reduction in pressure within the carbonated water line between the carbonator outlet and the valve inlet while carbonated water is being drawn.

The amount of pressure drop will vary with the length of the line, size of the tubing used, (inside Diameter), the rise of the line, and the flow of the carbonated water through the line, (gallons per hour).

Carbonated water lift pressure is .45 pounds per foot rise.

The pressure drop within a carbonated water line should not exceed 30 P.S.I.

When soda lines are run more than 10 feet in any one direction a minimum of 3/8" tubing is recommended. When soda lines are run more than 50 feet 1/2" tubing is recommended.

When syrup lines are run more than 50 feet in any one direction a minimum of 3/8" tubing is recommended.

Braided Plastic Tubing – The flexible braided plastic tubing is used for carbonated water as well as all syrup lines. It will withstand high pressure and is easily installed because of its flexibility but should never be used in contact with hot water or steam lines.

## CHAPTER II

### INSTALLATION

This chapter covers unpacking and inspection, selecting location, installing LE MONSTRE and related components, connecting water inlet and electrical requirements.

#### UNPACKING AND INSPECTION

Upon receiving unit, immediately remove unit from shipping carton and inspect for shipping damage.

**NOTE:** Before leaving the factory all LE MONSTRE units were carefully inspected and the carrier has accepted and signed for them. Any damage or irregularities should be noted at the time of delivery and immediately reported to delivering carrier. Request a written inspection report from claims inspector to substantiate any necessary claim. File claim with delivering agency, not International Carbonic Inc.!

Unpack LOOSE-SHIPPED PARTS. At this time make sure all parts listed are present and in good condition. If any parts are missing, notify factory.

TABLE 2-1

#### LOOSE - SHIPPED PARTS

Item No.	Part No.	Name	Qty
1		Installation/Service Manual	1
2*	S-101	High Pressure C02 Regulator	1
3*	S-221	Low Pressure C02 Regulator	1
4	S-105	6' Gas Line (Inner Braid)	1
5*	S-208	Water Pressure Regulator	1
6*		Water filter	1
7	S-208-A-3/8	Water Pressure Regulator	1

\* Optional

#### SELECTING LOCATION

**IMPORTANT:** Ambient temperature for LE MONSTRE should not exceed 100 degrees "F". Operation of cooling unit in ambient above 100 degrees "F" can and will contribute to early failure of condensing unit and poor quality of finished product.

## LOCATION RECOMMENDATIONS FOR LE MONSTRE

1. Position unit as close as possible to proper electrical source, 120V 60HZ.
2. Position unit with a minimum of 2" space between bulkhead and cabinet for sufficient ventilation. Allow enough space between ceiling and unit for lid removal.
3. Position unit as close as possible to water source. Half inch gate valve recommended for water connection.
4. Enough space must be allowed to install C02 cylinder, syrup containers, racks, pumps, water filter, etc.
5. Position unit as close as possible to floor drain.

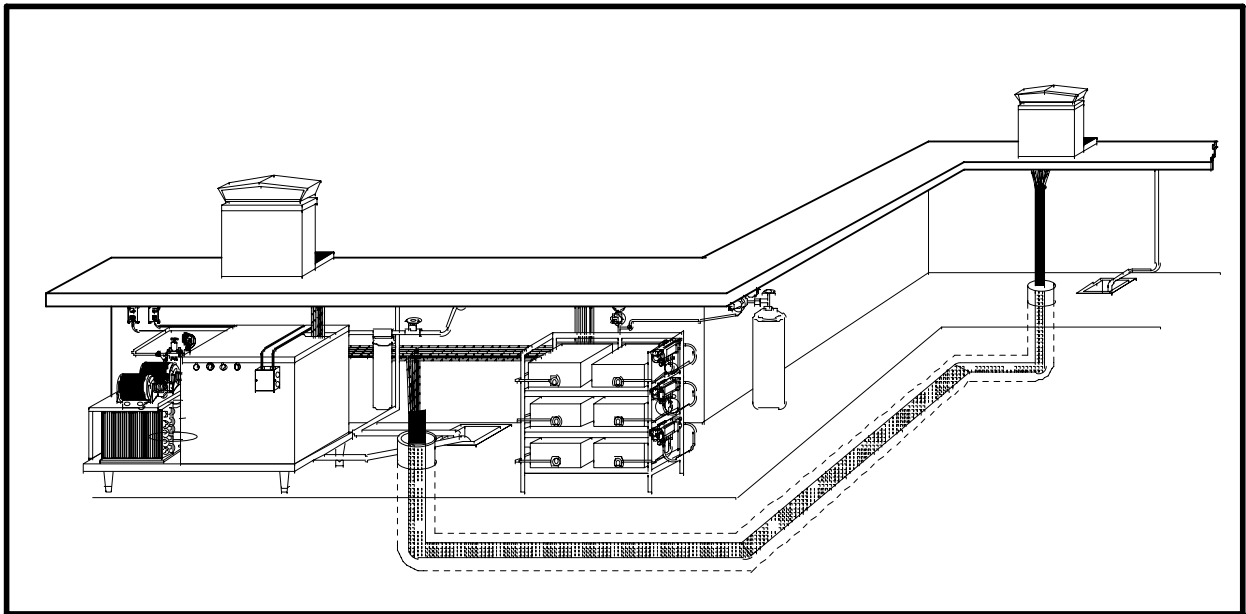

FIGURE 2-1. SAMPLE OF POSSIBLE INSTALLATION.

### INSTALLATION

1. Make all connections: C02 gas, plain water and syrups.
2. Place LE MONSTRE in position. Make sure sufficient space between bulkheads, walls and overheads is available for proper air circulation around cooling unit.

INSTALL HIGH PRESSURE CO2 REGULATOR, CO2 CYLINDER AND LINES  
(FOR CARBONATED UNITS ONLY)

1. Install high pressure CO2 regulator, (S-101) on CO2 cylinder using a new seal gasket.

MAKE SURE NEW WASHER IS INSIDE REGULATOR ASSEMBLIES COUPLING NUT BEFORE CONNECTING TO CYLINDER.

WARNING:- To avoid personal injury and/or property damage, always secure CO2 cylinder with safety chain to prevent cylinder from falling. It is recommended that the CO2 cylinder be installed away from heavily traveled areas such as doors, passageways, corridors, etc.

2. Connect 1/4" inner braided plastic tubing from outlet of high pressure CO2 regulator, (S-101), on CO2 cylinder to Tee connection at low pressure regulator, (S-221), using prefabricated gas charging line, (S-105).
3. A line must be fabricated at this time. Cut inner braid tubing to size and install nipple, (S-145), and nut, (S-150), to each end of tubing making sure either oetiker or ferrule is previously installed on line. Secure these connections by use of proper tool. Connect 1/4", inner braid plastic tubing from outlet of tee at low-pressure regulator, (S-221), (optional furnished with unit), to supplied line from unit marked gas.

INSTALL LOW PRESSURE REGULATOR AND LINES (OPTIONAL)

1. Install low pressure CO2 regulator on the wall or another supporting structure in general vicinity of cooling unit, CO2 cylinder, B.I.B. Rack or syrup tanks.
2. Connect 1/4" inner braided plastic tubing from outlets of low pressure CO2 regulator, (S-221), to inlets of B.I.B. pump or syrup tanks.

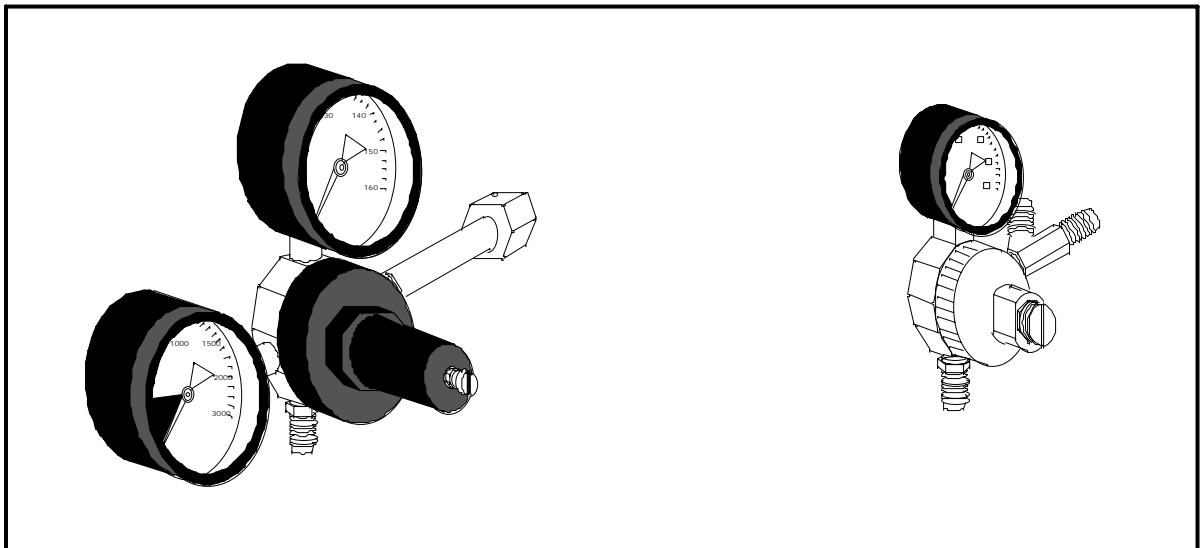

FIGURE 2-2  
HIGH PRESSURE CO2 REGULATOR  
REGULATOR

(S-101)

FIGURE 2-3  
LOW PRESSURE CO2  
REGULATOR

(S-221)

### INSTALL WATER FILTER ASSY. (OPTIONAL)

1. Install water filter assembly on wall or other supporting structure.
2. Connect water filter assembly to inlet of valve on water supply line using minimum 3/8" I.D. water line.
3. Connect water filter assembly outlet to LE MONSTRE plain water inlet fitting using minimum 3/8" I.D. water line. See CONNECTING WATER INLET.

When a water filter is used, it is important that it has a minimum 100 gallons per hour capacity and should be thoroughly flushed before it is connected to the water inlet connection.

### INSTALL WATER PRESSURE REGULATOR (OPTIONAL)

If water pressure exceeds 40 psi, a water pressure regulator or water pressure reducing valve should be installed in the water supply line and adjusted to maintain a pressure of 25 to 40 psi. (The water regulator must have an orifice of at least 3/16" so as not to restrict the water flow through the valve. Valves that are built with 1/2" pipe thread connection usually have a sufficient orifice opening.)

### INSTALL WATER HOLDING TANK (OPTIONAL)

When no water pressure is available or where the water supply system is inadequate, a water holding tank may be installed above the pump level. The pump will pump water from the holding tank to the carbonator.

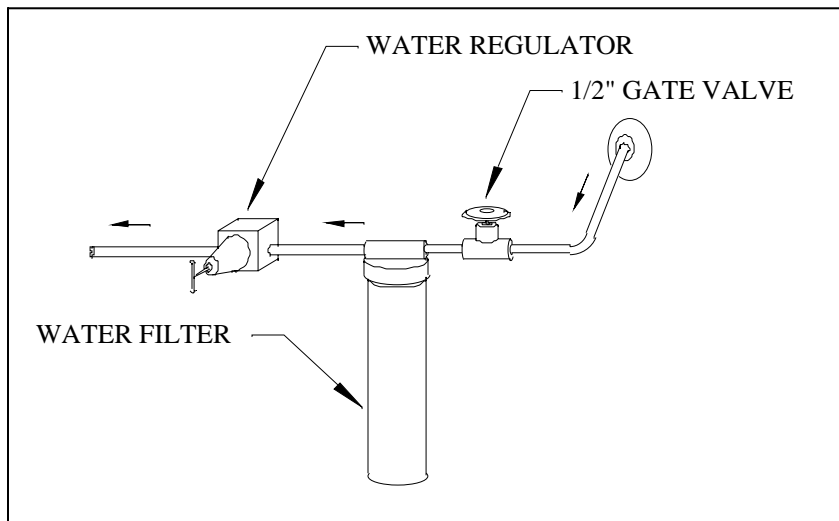

FIGURE 2-4. SUGGESTED WATER FLOW INSTALLATION

### INSTALL DRAIN LINE

1. Connect drain line on LE MONSTRE unit with drain using 1" I.D. clear plastic pipe or 1" PVC to nearest outlet.
2. Do not reduce drain connection from cabinet outlet.
3. Be sure all connections are water tight.

### INSTALL B.I.B. OR SYRUP TANKS AND ACCESSORIES (OPTIONAL)

1. Place B.I.B. or syrup tanks as close as possible to LE MONSTRE unit, preferably no farther than 5 feet.
2. Lay out syrup lines from unit to syrup pumps or tanks.
3. Connect lines from low-pressure regulator for B.I.B. or transfer tank installations.
4. Connect line from low-pressure regulator to Q.C.D. for B.I.B. or install quick disconnect for transfer tank type installations.
5. Install incoming syrup line to unit on Q.C.D. for B.I.B.
6. Install quick disconnect on incoming line to accommodate transfer tank installs.
7. Activate Q.C.D. or install quick disconnects to transfer tanks.
8. Check all connections for leaks, (see Chapter IV).

### CONNECTING WATER INLET

#### **WATER PIPE CONNECTIONS AND FIXTURES DIRECTLY CONNECTED TO POTABLE WATER SUPPLY SHALL BE SIZED, INSTALLED AND MAINTAINED ACCORDING TO FEDERAL, STATE, AND LOCAL LAWS.**

The water connection on the LE MONSTRE is made to a flexible water line by means of a 3/8", male flare. Due to the large capacity of the pump, any restriction of the incoming fresh water supply would starve the water pump and create noise within the pump, poor carbonation and extremely long running time.

After all primary water lines are made up, but prior to connecting water supply to cabinet, be sure to thoroughly flush all incoming water lines to remove all scale and any impurities that may be in the lines. It is important to remember that the LE MONSTRE has a carbonator capacity of a minimum of 100 gallons per hour. Therefore, it is imperative that the fresh water conduit have not less than 3/8" I.D. passageway for any distance greater than ten feet from the LE MONSTRE. It can be reduced to 3/8" O.D., copper tubing and connected to the water inlet connection with-in ten feet of the LE MONSTRE. All water inlet connections are clearly tagged.

### ELECTRICAL REQUIREMENTS:

The LE MONSTRE requires a 120 VAC, single phase, 60 Hertz power circuit, and must be wired in accordance with N.E.C. or local ordinance.

NOTE: Check CHAPTER I for running amperage and connect to appropriate electrical circuit.



## CHAPTER III

### PREPARATION

All steps in previous chapters should be understood and carried out before proceeding.

#### PREPARING SYSTEM FOR OPERATION

Be sure that electrical power is unplugged, valve on CO<sub>2</sub> cylinder is closed, valve on water supply line is closed, and release pressure of CO<sub>2</sub> gas and water from carbonator tank.

#### PREPARING AND STARTING REFRIGERATION UNIT

1. LE MONSTRE refrigeration is pre-set at factory and ready to operate.
2. Remove lid.
3. Fill water bath with clean water until water runs out of drain standpipe, (S-487).

IT IS RECOMMENDED LOW-MINERAL-CONTENT OR DISTILLED WATER BE USED IN WATER BATH.

4. Open water inlet supply line.
5. Plug LE MONSTRE power cord into electrical receptacle box. Make sure compressor, condenser fan motor, agitator motor start. The process of cooling the water bath will now commence. With ambient and water temperature of 75 degree "F" initial pull down or formation of complete ice bank will take approximately 4 - 5 hrs. When full ice bank has been formed, compressor and condenser fan motor will stop. Agitator will continue to operate, circulating water in water bath.

#### ACTIVATE HIGH PRESSURE CO<sub>2</sub> SYSTEM

1. Open valve on the CO<sub>2</sub> cylinder. Be sure to open valve completely or until valve is back seated.
2. Turn high pressure CO<sub>2</sub> regulator screw clockwise until the pressure is 65 to 75 psi. Carbonated units only.
3. Dispense water from dispensing valves until the carbonator activates. Carbonated units only.
4. Allow carbonator to run until it automatically shuts off. Pump is fully primed and carbonator is now ready for use. Carbonated units only.
5. Check all connections on high pressure CO<sub>2</sub> system for leaks. Repair any leaks that are found.

### ACTIVATE LOW PRESSURE CO2 GAS AND SYRUP SYSTEMS (OPTIONAL)

1. Make sure high pressure CO2 regulator pressure is 65 to 75 psi.
2. Make sure all B.I.B. racks or syrup tanks are full.
3. Make sure all Q.C.D.,s are in a operational position or gas and syrup quick disconnects are connected tightly with syrup tanks.
4. Turn low pressure CO2 regulator screw clockwise until the pressure is approx. 40 psi for B.I.B. and approx. 30 psi for FIGAL.

NOTE: These pressures will vary depending on baume of product, type of pumps, etc.

5. If diet drink regulator is required turn CO2 diet drink pressure regulator screw clockwise until the pressure is 6 to 10 psi.
6. Dispense syrup from dispensing valves until all air is purged from syrup lines and syrup is dispensed.
7. Check for syrup and gas leaks. Repair any leaks that may be found.

### ADJUST WATER FLOW RATE

Adjust dispensing valves water flow rate as instructed in chapter IV, OPERATORS INSTRUCTIONS.

### ADJUST WATER-TO-SYRUP "RATIO"

Adjust dispensing valves for Water-to-syrup "Ratio" of dispensed product as instructed in chapter IV, OPERATOR INSTRUCTIONS.

### ADJUST SIZE OF DRINK DISPENSED (FOR PORTION CONTROL VALVES-PCT ONLY)

Adjust size of drink dispensed as instructed in chapter IV, OPERATOR INSTRUCTIONS.

## CHAPTER IV

### OPERATORS INSTRUCTIONS

This chapter covers operator's responsibilities for daily pre-operation check, adjustments, replenishing CO<sub>2</sub> and syrup supplies, cleaning, and sanitizing.

#### DAILY PRE-OPERATION CHECK

1. Make sure high pressure CO<sub>2</sub> regulator's pound per square inch indicator is not in shaded portion of dial. If so, CO<sub>2</sub> cylinder is almost empty and must be replaced.

NOTE: This reading should be carried out at normal room temperature.

Make sure there is a sufficient syrup supply in all syrup containers. If not, replenish syrup supply.

#### REPLENISHING CO<sub>2</sub> SUPPLY

NOTE: If pound per square inch indicator of high pressure CO<sub>2</sub> regulator on CO<sub>2</sub> cylinder is in shaded portion of the dial, CO<sub>2</sub> cylinder is almost empty and should be changed.

CO<sub>2</sub> supply must be checked daily and if necessary, replenished as instructed (see CHAPTER II).

#### REPLENISHING SYRUP SUPPLY

Syrup supply must be checked daily and if necessary, replenished as instructed (see CHAPTER II).

#### COOLING UNIT MAINTENANCE

NOTE: Air circulation through the condenser coil, required to cool the condenser coil/compressor, is drawn in through grills on the cooling unit, through condenser coil and is exhausted out grills on the sides of the unit. Restricting air circulation through the cooling unit will decrease its cooling capacity.

To avoid needless and sometimes costly repairs, it is imperative to keep condenser fins clean. This may be accomplished by one of three methods. One method is use of a condenser brush (a longhaired, soft bristle brush) to gently sweep fins of condenser clean. Second method is to use a strong vacuum. The third method is to use CO<sub>2</sub> or an air hose to blow out condenser. The latter method should only be attempted after normal business hours to avoid dust contamination.

## CHECKING WATER BATH

Periodically check water level in water bath. If it is low more water should be added as instructed for maximum product cooling. This dehydration will normally not occur in normal temperate climate zones. With normal humidity the opposite will occur therefore a condensate drain is installed. Any extra water in the water bath will exit the unit via the drain outlet. When unit is building it's first ice bank it is normal to have water overflow the into the drain hose.

## CHANGING WATER BATH

Drain water bath a minimum of twice a year. This can be accomplished by siphoning water with short hose into bucket or removing over flow standpipe. Once water is drained and ice bank is melted, water bath, water coils, bath walls, tank, etc. should be cleaned. Fill water bath to the top of the standpipe, (S-487).

## ADJUSTMENTS

Periodically C02 regulators should be checked for proper pressure settings and if necessary, adjust as instructed. These settings can be recorded in NOTE section of this manual.

### ADJUSTING WATER FLOW RATE

If adjustment of water flow rate should be necessary, adjust as instructed.

### ADJUSTING WATER-TO-SYRUP RATIO, "BRIX", OF DISPENSED PRODUCT

Water-To-Syrup BRIX" of dispensed product should be checked and if necessary, adjust as instructed.

### ADJUSTING SIZE OF DRINK DISPENSED (FOR PORTION CONTROL VALVES-PCT ONLY)

Drink size of dispensed product should be checked and if necessary, adjust as instructed.

## TESTING FOR LEAKS

1. Completely back off adjusting screw on low pressure C02 regulator.
2. Close valve on top C02 cylinder.
3. Wait for 5 minutes or more. If pressure on high pressure gauge decreases excessively, there is leak in the carbonator circuit.

4. All connections including cylinder valve should be coated with a soap solution. If bubbles appear a leak is apparent.

5. Always be sure that the low pressure adjusting screw is completely backed off before testing carbonator circuit for leaks. Otherwise, gas going into syrup tanks would cause this high pressure gauge needle to balance with pressure in syrup tanks, which would be a false indication of a leak in the carbonator circuit.

6. After it has been determined that there are no leaks in the carbonator circuit, open CO<sub>2</sub> cylinder valve and adjust low pressure regulator to 15 psi. Allow enough time for the syrup tanks to fill completely with gas, (5 minutes or longer).

7. Next, completely back off low-pressure regulator adjusting screw, and if gauge needle of low-pressure regulator commence to move downward, there is leak in the low-pressure circuit. Check all connections with a soap solution, paying particular attention to syrup tank covers. If low pressure gauge needle remains stationary, there is no leak.

## CHAPTER V

### SERVICE AND MAINTENANCE

This chapter describes service and maintenance procedures to be performed on LE MONSTRE units and related components.

#### PERIODIC INSPECTION AND CLEANING

##### Daily:

1. Clean any syrup from storage tanks/B.I.B. racks, connecting sockets/Q.C.D.s and general syrup storage area with warm water.
2. Check the C02 gas supply. If cylinder pressure is below 500 P.S.I., replace the cylinder.

NOTE: Readings should be taken at normal room temperature, approximately 70 degrees "F" and above. If C02 cylinder is stored in a walk-in refrigerator, the P.S.I. indicator will read below 500 psi even when cylinder is full.

3. Check the C02 gas pressure supplying the carbonator and syrup tanks. These pressures should not change. If a change occurs repeatedly, contact your local service agency. It is suggested to make a comment about this occurrence in NOTE SECTION of manual.
4. Clean the beverage dispensing area.
5. Remove and clean nozzles and all exposed areas on valves.
6. Wipe exterior of unit with moist towel. Stainless cleans well with carbonated water.

##### Weekly:

1. Order syrup to maintain proper inventory.
2. Check all C02 gas connections for leaks.
3. Measure the water-to-syrup ratio on all beverages, adjust ratio if necessary.
4. Check condenser coil for obstructions or dirt.

##### Monthly:

1. Clean condenser fins or filter to make sure the refrigeration unit has adequate air flow.
2. Inspect components of cooling unit water bath for cleanliness.
3. Check entire system for leaks or damaged components. Repair as necessary.

## LE MONSTRE CABINET MAINTENANCE

### PERIODIC CLEANING

Periodically wash all external surfaces of LE MONSTRE cabinet, rinse with clean water, then wipe dry with a clean soft cloth. DO NOT USE ABRASIVE TYPE CLEANERS.

### CLEANING CONDENSER COIL

**IMPORTANT:** Air circulation through the condenser coil is required to cool the compressor. Air is drawn in through grills on the top of the cooling unit, through condenser coil and exhausted out grills on the top of unit. Restricting air circulation through the cooling unit will decrease its cooling capacity.

**NOTE:** Cleaning condenser coil should be done during non-use periods.

1. Unplug refrigeration unit power cord from electrical socket.
2. Remove service panels.
3. Vacuum or use a soft brush to clean fins of condenser coil. Use low-pressure compressed air or CO<sub>2</sub> gas to blow through condenser fins. This should only be performed after normal business hours to prevent dust contamination. A damp cloth on backside of condenser coil will prevent some dust contamination
4. Replace service panels.
- S. Plug LE MONSTRE power cord in electrical socket.

### CHECKING / CHANGING WATER BATH

Periodically check water level in water bath. If it is low, more water should be added for maximum product cooling. Before adding more water, water bath and ice bank should be checked for excessive mineral deposit build up.

**NOTE:** The water in water bath should be changed and all components in water bath should be cleaned as often as necessary to keep it clean. A convenient time to perform this operation is when the system is being sanitized.

1. Unplug refrigeration unit power cord from electrical socket.
2. Remove lid from unit.
3. Look down into water bath (if necessary, use flashlight) and inspect water bath, ice bank and all components for cleanliness. Water, ice bank and all components should be clear and free of foreign particles. If ice bank is clear of foreign particles, it does not have to be melted down. Proceed to step 10., if foreign particles are present in the ice bank, proceed to step 4.
4. Siphon out water with short hose or pull out over flow stand pipe.
5. Allow ice bank to melt. Hot water may be used to speed melting.

**CAUTION:** Never use an ice pick or other sharp instruments to remove ice from evaporator coil. Such practice can result in puncture to the refrigeration circuit.

6. Use fiber brush and carefully clean mineral deposit from all components.
7. Wash evaporator coil with a mild soap solution. Copper cleans well with mild solution of citric acid (1 cup of citric acid for 2 gallons of water). Stainless steel cleans well with carbonated water. Then rinse with clean water.
7. Rinse out water bath with clean water until water running out of siphon hose is clean.
9. Insert standpipe in drain hole
10. Fill water bath to top of standpipe.
11. Replace lid.
12. Plug refrigeration unit power cord in electrical socket.

### WATER PUMP MAINTENANCE

**Warning:** The water pump inlet strainer screen must be inspected and serviced at least once a year under normal circumstances or after any disruptions (plumbing work, earthquake, etc.), to the water supply systems that might cause clogged flow of water through system. Water pump with no screen or a defective screen in the strainer would allow foreign particles into water system and create a health hazard.

1. Unplug power cord from electrical socket.
2. Shut off plain water supply to water pump by closing shutoff valves in water supply line.
3. Shut off CO2 supply to LE MONSTRE by closing shutoff valve on CO2 cylinder.
4. Remove lid from unit.
5. Gain access to water bath.
6. Pull up on carbonator tank relief valve to relieve CO2 pressure from tank.
7. Go to carbonator motor "Y" strainer and remove screen retainer.
8. Pull screen retainer and water strainer screen out of water pump port.
9. Clean any sediment from screen retainer and water pump port.
- 10. Inspect water strainer screen for holes, restrictions, corrosion, and other damage. A water strainer screen should always be used, other wise particles could damage pump and foul the double check valve.**
11. Check "O" ring on screen retainer. Replace worn or damage "O" ring.



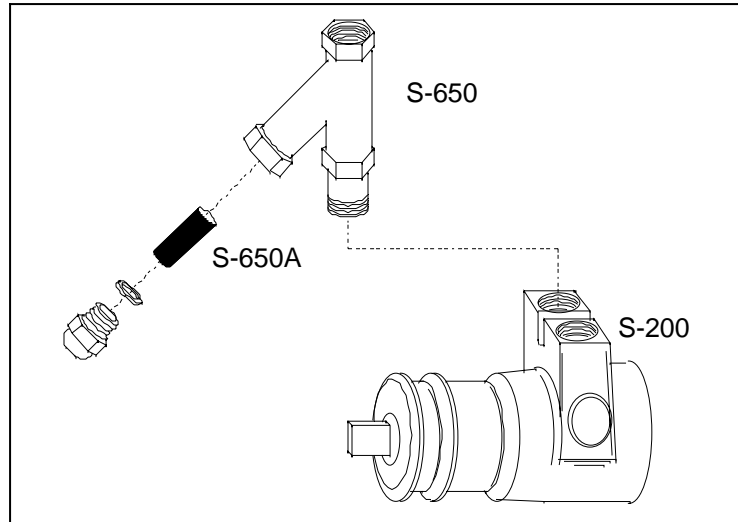

FIGURE 5-1  
WATER PUMP, "Y" STRAINER & SCREEN

### CARBONATOR MAINTENANCE

1. Unplug refrigeration unit power cord from electrical socket.
2. Remove lid from unit.
3. Look down into water bath (if necessary, use flashlight) and inspect carbonator tank for leak. Air bubbles will arise from place of leak, if leak is below surface of water. If leak is above surface of water soap bubbles should be used to find any leak.
4. Shut off plain water supply to water pump by closing shutoff valve in water supply line.
5. Shut off C02 supply to refrigerating unit by closing shutoff valve on C02 cylinder.
6. Pull up on carbonator tank relief to relieve C02 pressure from tank.
7. Eliminate leak, tighten bad connections, or replace defective Probe assembly, water double check valve, (S-20), gas single check valve, (S-22), or valve relief, (S-215).
8. Service check valves as outlined in SERVICING CHECK VALVES.
9. Reassemble as necessary.
10. Replace lid.
11. Plug refrigeration unit power cord in electrical socket.
12. Turn on plain water supply to water pump by opening shutoff valves in water supply line.
13. Turn on C02 supply to refrigerating unit by opening shutoff valve on C02 cylinder.
14. Activate all systems as outlines in CHAPTER III.

### LUBRICATION

Water pump motors bearing must be oiled periodically. Refer to oiling instruction on motors. DO NO OVER OIL.

## SERVICING CHECK VALVES

It is not recommended to disassemble the check valves unless it is absolutely necessary. As stated before this necessity would be prompted by earthquakes, disruption of water service, etc.

The symptoms of a malfunctioning check valve would be:

Water check valve

Carbonation through out water supply, i.e., basins, toilets, etc. or an activated vent valve.

Gas check valve

Water in C02 cylinder, water escaping from high pressure C02 regulator, (S-101), during cylinder change and possibly water in syrup containers. If any of the above symptoms occur proceed with the following:

1. Disconnect water line from double check valve outlet. Remove double check from water pump outlet fitting.
2. Remove one check valve from other, then disassemble each check valve as shown in Figure 5-2.
3. Wipe each part with clean lint-free cloth. Inspect each part, especially the ball, for burrs, nicks, corrosion, deterioration, and other damage. Discard ball "O"-ring, (S-13), and any damaged or suspicious parts and replace with new parts during re-assembly.
4. Reassemble each check valve as shown in Figure 5-2.

ALWAYS INSTALL NEW "O" RING, (S-13).

5. Assemble check valves together as shown in Figure 5-1.
6. Connect water inlet line to double check valve assembly.
7. Activate the system as outlined in CHAPTER III.

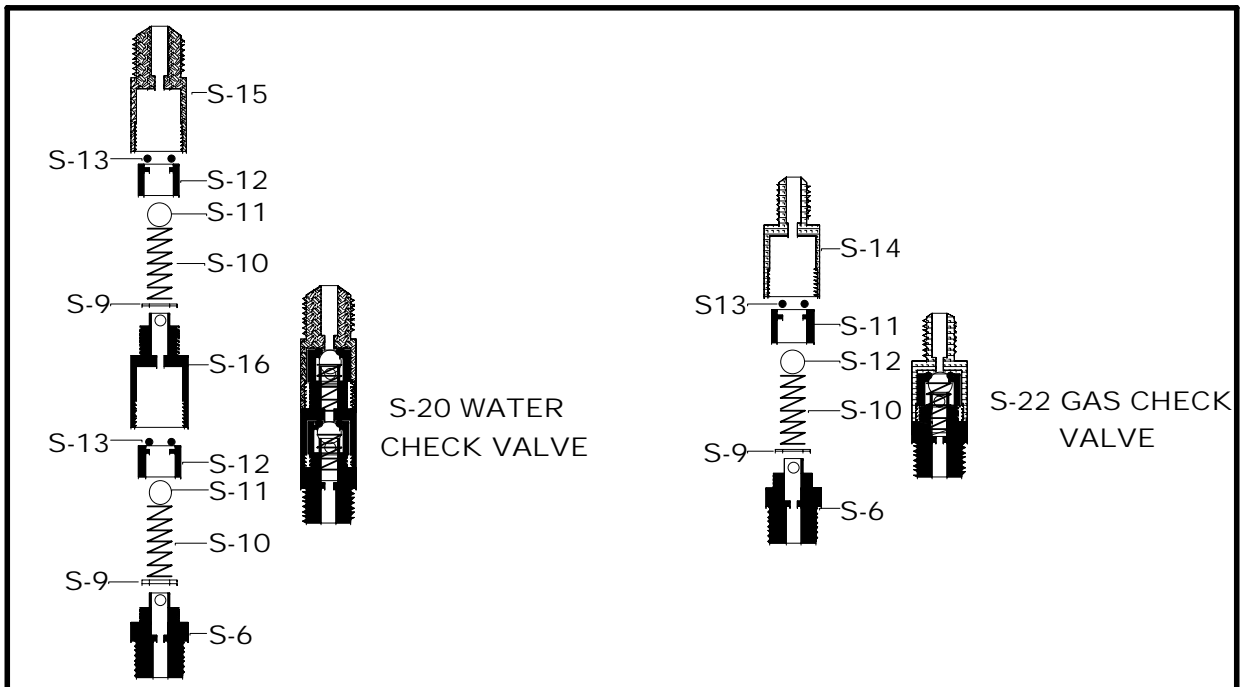

FIGURE 5-2 CHECK VALVES

SYM	QTY	PART NO.	DESCRIPTION
1	1	S-14	HOUSING, CHECK VALVE 1/4" M.F.
2	3	S-13	SEAT "O" RING CHECK VALVE
3	3	S-12	SLEEVE, SEAT RETAINER CHECK VALVE
4	3	S-11	BALL, CHECK VALVE
5	3	S-10	SPRING, CHECK VALVE
6	3	S-9	GASKET, CHECK VALVE
7	2	S-6 1/8	BODY, BASE, CHECK VALVE
8	1	S-16	ADAPTOR HOUSING, DOUBLE CHECK VALVE
9	1	S-15	HOUSING, CHECK VALVE 3/8" M.F.
10	1	S	1/4" M.P.I., S.S. INLET
11	1	-	PLUNGER WITH SEAT
12	1	2	SPRING, 275 P.S.I.
13	1	1	SAFETY UPPER CAP
14	1	5	LEVER HANDLE
15	1	1	LEVER PIN
		8	

S-229

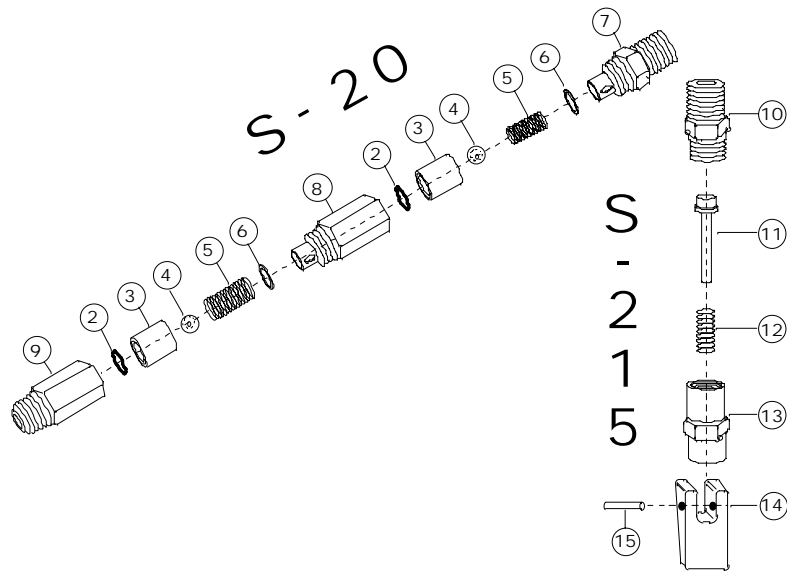
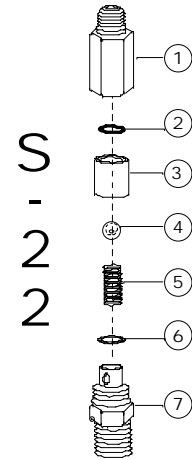

FIGURE 5-3. EXPLODED VIEW CHECK VALVES

### REPLENISHING CO2 SUPPLY

1. Close empty CO2 cylinder shutoff valve.
2. Disconnect high pressure CO2 regulator, then remove empty CO2 cylinder
3. Install full CO2 cylinder and connect high pressure CO2 regulator. See installation procedure in CHAPTER II.

**MAKE SURE CO2 CYLINDER IS POSITIONED IN UPRIGHT POSITION AND FASTENED WITH SAFETY CHAIN. ALWAYS OPEN CO2 VALVE COMPLETELY OR UNTIL BACK SEATED DURING OPERATION. WHEN BOTTLE IS EMPTY ALWAYS CLOSE VALVE ASSEMBLY COMPLETELY.**

### REPLENISHING SYRUP SUPPLY

1. Remove Q.C.D.s from empty B.I.B. or syrup & CO2 quick disconnects from empty syrup tank.
2. Install full syrup container in position, rinse Q.C.D.s or quick disconnects in warm water, then connect Q.C.D.s or syrup & CO2 quick disconnects to tank.
3. Activate valve until syrup flows from valve normally. See CHAPTER II.

### SYRUP FLAVOR CHANGE

1. Remove Q.C.D.s from applicable B.I.B. or syrup quick disconnects from applicable syrup tank.
2. Sanitize applicable syrup system in accordance with instructions. See paragraph CLEANING AND SANITIZING in this chapter.
3. Install full syrup container in position, rinse Q.C.D.s or quick disconnects in warm water, then connect Q.C.D.s or syrup & CO2 quick disconnects to container.
4. Activate valve until syrup flows from valve normally. See CHAPTER II.

### CHANGING WATER FILTER CARTRIDGE

Follow manufacturer's instructions for water filter.

### ADJUSTMENTS

#### HIGH PRESSURE CO2 REGULATOR

The high-pressure CO2 regulator will have two gauges that extend above and to the side of the bell housing screw area. The P.S.I. gauge will show graduated indications up to 3000 psi and be the gauge the farthest from the CO2 cylinder connection. This gauge will normally have a Red area indicating 500 psi to 0 psi. This gauge will be used to check volume of liquid in the CO2 cylinder. The other gauge will show regulated pressure that will be delivered to the LE MONSTRE carbonation system. This gauge can be indicated from 0-160 psi up to 0-300 psi. By turning the high-pressure regulator adjustment screw clockwise we will increase pressure supplied to our carbonator which will be indicated on this gauge. To lower pressure to carbonation system it is recommended that the adjustment screw be turned counter clockwise several full turns and then the relief valve, (S-215), be lifted lowering pressure in carbonating system, now readjust. When adjusting CO2 high-pressure regulator a setting of 65-75 psi is recommended.

INLET CO2 PRESSURE TO CARBONATION SYSTEM SHOULD NOT EXCEED 75 PSI

LOW PRESSURE CO2 REGULATOR

The low-pressure CO2 regulator setting can and will vary dramatically from one installation to the next. Variables such as distance from syrup containers to point of serving, horizontal or vertical runs, baume of product, to whether B.I.B. or transfer tanks are used will influence where the low pressure regulator is adjusted.

A good starting point as an adjustment is:

40 psi for B.I.B.

and

30 psi for transfer tanks.

**NOTE: After primary adjustment on low pressure regulator always go to farthest serving station from syrup storage area and adjust heaviest baume syrup (normally ORANGE). If adjustment can be made proceed with all other flavors.**

DIET SYRUP TANK CO2 REGULATOR S-121

The diet CO2 regulator is normally used only on transfer tank installations and should be set from 6 to 10 psi depending on length of run. In some cases where a vertical run is encountered pressure may be set as high as 15 psi. Excessive CO2 pressure may cause diet syrup to carbonate resulting in foam.

## SANITIZING PROCEDURES

Your local health department rules and general area cleanliness should determine the frequency at which the unit should be sanitized.

### EQUIPMENT REQUIRED:

1. Stainless Steel containers (product tanks), or large volume container.
2. CO2 Supply If applicable (Same as used with dispensing unit).
3. Cleaning Agent.
4. Sanitizing Solution.
5. Phenolphthalein.

NOTE: One recommended cleaning agent and sanitizing agent is manufactured by:

MT. HOOD CHEMICAL CORP.  
4444 N.W. Yeon Avenue  
Portland, Oregon 97210

Trade names are: STAR - CHLORINATED CLEANER  
CROWN - 12.5% SODIUM HYPOCHLORITE BLEACH

Use STAR at 18 oz. per 1 gallon of water yields 2% Sodium Hydroxide Solution.

Use Crown at 2 ounce per 9 gallons of water (gives 200 PPM of available chlorine) at a minimum contact time of 10 minutes.

1. Disconnect syrup containers and remove product from tubing by purging with carbon dioxide or flushing with warm water.
2. Visually inspect valve by removing nozzle and inspecting nozzle and valve cavity. Clean nozzle with cleaning agent, then sanitizing solution, then with potable water. Inspect valve cavity and if dirty clean with soft bristle brush. Clean exteriors of valve with a soft cloth and warm water. Replace valve nozzle then go to step #3.
3. Fill syrup lines with a caustic-based (low sudsing, non-perfumed, and rinsed) detergent solution, (STAR). The solution should be prepared in accordance with the manufacturers recommendations, but should be at least 2 percent sodium hydroxide. Make sure the syrup lines are completely filled and allow standing for at least 10 minutes.
4. Flush the detergent solution from the syrup lines with clean water. Continue rinsing until testing with phenolphthalein shows that the rinse water is free of residual detergent.
5. Fill the syrup lines with a low PH (7.0) chloride solution containing maximum 200-PPM chlorine. Make sure that lines are completely filled and allow standing for 30 minutes.
6. Reconnect syrup containers and ready Unit for operation.
7. Draw drinks to refill syrup lines and flush the chloride solution from the dispenser.
8. Taste the beverage to verify that there is no off taste.

NOTE: WHEN SANITIZING A TWO FLAVOR VALVE BOTH SYRUPS SHOULD BE FLUSHED SIMULTANEOUSLY, BOTH SYRUPS SHOULD BE CLEANED, (DETERGENT SOLUTION), SIMULTANEOUSLY, BOTH SYRUPS SHOULD BE FLUSHED UNTIL FREE OF DETERGENT SIMULTANEOUSLY AND BOTH SYRUPS SHOULD BE SANITIZED SIMULTANEOUSLY.

**TROUBLE SHOOTING**

**IMPORTANT:** Only qualified personnel should service the LE MONSTRE unit and components.

**WARNING:** To avoid personal injury and or property damage, always disconnect electrical power, shut off plain water and CO2 supplies before starting any repairs. If repairs are to be made to the carbonated water system, bleed carbonated water system pressure before proceeding. If repairs are to be made to syrup system, remove quick disconnects from syrup tanks, or remove QCD from BIB, then bleed system pressure before proceeding.

**CARBONATOR**

Trouble		Probable Cause		Remedy
Water pump motor will not operate	1. 2. 3. 4. 5.	Inoperable water pump/ motor. Overheated motor (cut off by thermal overload protector). Electrode inside carbonator tank defective. L.L.C. assembly Inoperable. Loose electrical connection and/or open electrical circuit. Defective pump protector, S-103	1. 2. 3. 4. 5.	Replace water pump/ motor. Check for proper line voltage. Allow motor time to cool. Replace carbonator tank electrode. Replace L.L.C. assembly. Tighten connection and/or repair open circuit. Check line voltage. Replace pump protector
Water pump motor will not shut off	1. 2. 3. 4. 5.	Defective water pump. Electrode inside carbonator tank defective. L.L.C. assembly inoperable. Loose electrical connection and or open electrical circuit. Carbonated water leak.	1. 2. 3. 4. 5.	Replace water pump. Replace carbonator tank electrode. Replace L.L.C. assembly. Tighten connection and or repair open ground circuit. Find and repair leak.
Water Pump motor will not shut off and pressure relief engaged	1. 2.	Electrode inside carbonator does not sense ground. L.L.C. assembly inoperable.	1. 2.	Replace defective electrode or check and tighten ground connection at control box. Replace L.L.C. assembly.
Short cycling of water pump motor	1. 2. 3.	Ground connection loose or disconnected. Electrode inside carbonator tank defective. Carbonated water leak in system. L.L.C. assembly inoperable.	1. 2. 3.	Attach or tighten ground connection. Replace carbonator tank electrode. Repair carbonated water leak. Replace L.L.C. control assembly.
Water pump capacity to low	1. 2. 3. 4.	Inlet water volume supply to low. Water motor/pump worn out. Kinked or restricted water supply line. Foreign object in water pump or restriction to water pump.	1. 2. 3. 4.	Increase diameter of supply line, install holding tank. Replace water pump. Clear or replace restricted water supply line. Clear restrictions and check pump strainer for debris.
Water pump operates but water pump does not pump	1. 2. 3. 4.	Water supply to low or turned off. Inoperative water pump. Water supply filter clogged. Water pump strainer clogged.	1. 2. 3. 4.	Inlet water supply must be a minimum of 3/8". Replace water Pump. Replace filter. Clean water pump strainer.

Frozen water bath	<ol style="list-style-type: none"> <li>1.</li> <li>2.</li> <li>3.</li> <li>4.</li> </ol>	<p>Bad ice bank control. Refrigerant leak causing undercharge. Defective agitator motor. Dirty water bath.</p>	<ol style="list-style-type: none"> <li>1.</li> <li>2.</li> <li>3.</li> <li>4.</li> </ol>	<p>Replace bad ice bank control. Repair leak, evacuate and recharge. Replace defective agitator. Melt ice, empty &amp; clean bath. Replenish w/fresh water.</p>
Cooling or condensing unit non-operational	<ol style="list-style-type: none"> <li>1.</li> <li>2.</li> <li>3.</li> <li>4.</li> <li>5.</li> <li>6.</li> <li>7.</li> <li>8.</li> </ol>	<p>No electrical power. Defective ice bank control. Dirty condenser unit. Improper voltage/amperage Loss of refrigerant. Bad overload and relay. Compressor bad. Restriction (pinched or crimped line).</p>	<ol style="list-style-type: none"> <li>1.</li> <li>2.</li> <li>3.</li> <li>4.</li> <li>5.</li> <li>6.</li> <li>7.</li> <li>8.</li> </ol>	<p>Plug power cord into electrical box. Check on/off switch. Replace ice bank control. Clean condenser unit w/vacuum cleaner. Check for proper voltage/amperage. Repair leak and replenish refrigerant. Replace overload and relay Replace compressor. Repair, straighten or replace defective line.</p>
Agitator motor not operating	<ol style="list-style-type: none"> <li>1.</li> <li>2.</li> <li>3.</li> <li>4.</li> </ol>	<p>Agitator propeller obstructed or lost. Low voltage. Loose, unplugged, or broken wiring. Bad agitator motor.</p>	<ol style="list-style-type: none"> <li>1.</li> <li>2.</li> <li>3.</li> <li>4.</li> </ol>	<p>Remove obstruction or re-Attach propeller. Voltage must be at least 110 volt at terminals. Tighten connection or replace broken wiring. Replace agitator motor.</p>
Compressor does not operate	<ol style="list-style-type: none"> <li>1.</li> <li>2.</li> <li>3.</li> <li>4.</li> <li>5.</li> <li>6.</li> <li>7.</li> <li>8.</li> </ol>	<p>No power source. Electrical power to cooling unit turned off. Low voltage. Loose, disconnected, or broken wire. Inoperative ice bank control. Inoperative overload protector or start relay. Inoperative compressor. Full ice bank.</p>	<ol style="list-style-type: none"> <li>1.</li> <li>2.</li> <li>3.</li> <li>4.</li> <li>5.</li> <li>6.</li> <li>7.</li> <li>8.</li> </ol>	<p>Plug power cord to electrical box. Check line voltage. Turn on power switch to unit. Voltage must be at least 110 V at compressor terminals at start. Tighten connection or replace broken wiring. Replace ice bank control. Replace defective part. Replace compressor. Refrigeration not called for.</p>
Compressor works continuously but does not form sufficient ice bank	<ol style="list-style-type: none"> <li>1.</li> <li>2.</li> <li>3.</li> <li>4.</li> </ol>	<p>Cooling capacity is exceeded by over drawing. Cooling unit located in excessively hot area. Air circulation through condenser coil is restricted Loss of refrigerant or in-sufficient charge.</p>	<ol style="list-style-type: none"> <li>1.</li> <li>2.</li> <li>3.</li> <li>4.</li> </ol>	<p>Reduce amount of drinks taken per given time of install higher volume unit. Relocate cooling unit. Check and if necessary, clean condenser coil. Repair leak and/or recharge with sufficient refrigerant.</p>



Note: Ice bank freezes from bottom of evaporator upward. A refrigerant leak or insufficient charge might show ice at bottom and not at top of evaporator.				
Compressor will not stop after sufficient ice bank is produced	1.	Ice bank control capillary tube kinked or broken.	1.	Replace ice bank control.
	2.	Ice bank control stuck in closed position.	2.	Replace ice bank control.
Note: During overload protector shut off condenser fan motor will continue to work. Otherwise, troubleshooting condenser fan motor problems is the same as "Compressor does not operate", paragraph in addition to the following.				
Condenser fan motor not operating	1.	Electrical cord loose or disconnected from condenser fan motor or compressor terminals.	1.	Tighten connections or replace cord.
	2.	Fan blade obstructed.	2.	Remove obstruction.
	3.	Inoperative condenser fan motor.	3.	Replace condenser fan motor.
No syrup being dispensed	1.	Syrup container empty.	1.	Replenish syrup supply.
	2.	Syrup lines crimped.	2.	Straighten syrup lines.
	3.	CO2 cylinder empty.	3.	Change CO2 cylinder.
	4.	QCD of syrup installed incorrectly.	4.	Re-install QCD correctly.
	5.	Low pressure regulator defective or plugged.	5.	Repair or replace low pressure regulator.
	6.	Syrup disconnect not attached correctly.	6.	Lubricate and attach.
	7.	Loose electrical connection of syrup solenoid and or open electrical connection.	7.	Tighten connection and/or repair open circuit. Check proper voltage.
	8.	Frozen water bath.	8.	See "Frozen Water Bath".
No water being dispensed	1.	Plain water inlet supply shutoff closed.	1.	Open plain water inlet supply line shut off valve.
	2.	Water filter fouled/clogged.	2.	Replace filter or cartridge.
	3.	Pinched or crimped line.	3.	Repair defective line.
	4.	Loose electrical connection, 24 volt.	4.	Tighten connection and or repair open circuit.
	5.	Water pump motor worn out or damaged.	5.	Replace motor.
	6.	Water pump worn out or damaged.	6.	Replace water pump.
	7.	Frozen water bath.	7.	See "Frozen water bath".
Volumes of CO2 to low in finished product	1.	High pressure regulator out of adjustment.	1.	Adjust high pressure regulator as instructed.
	2.	CO2 cylinder empty.	2.	Replace CO2 cylinder.
	3.	Water, oil, or dirt in CO2 supply.	3.	Clean contaminated CO2 system, (lines, regulator, etc.) and sanitize as instructed.
	4.	Temperature above quality limits.	4.	See refrigeration/machine specifications vs. volume requirements.

Dispensed product makes foam as it leaves dispensing valve	<ol style="list-style-type: none"> <li>1.</li> <li>2.</li> <li>3.</li> <li>4.</li> </ol>	<ol style="list-style-type: none"> <li>1. Pressure of CO2 to high.</li> <li>2. Syrup over-carbonated with CO2.</li> <li>3. Dirty nozzle and valve cavity.</li> <li>4. Temperature above quality limits.</li> </ol>	<ol style="list-style-type: none"> <li>1.</li> <li>2.</li> <li>3.</li> <li>4.</li> </ol>	<ol style="list-style-type: none"> <li>1. Adjust high pressure regulator as instructed.</li> <li>2. Remove syrup tank quick disconnects. Relieve pressure; shake tank vigorously, as necessary to remove over-carbonation.</li> <li>3. Clean contaminated nozzle and sanitize as instructed.</li> <li>4. See refrigeration/machine specifications vs volume requirements.</li> </ol>
Dispensed product comes out clear but foams in cup or class	<ol style="list-style-type: none"> <li>1.</li> <li>2.</li> </ol>	<ol style="list-style-type: none"> <li>1. Oil film or soap scum in cup or glass.</li> <li>2. Ice used for finished drink is subcooled.</li> </ol>	<ol style="list-style-type: none"> <li>1.</li> <li>2.</li> </ol>	<ol style="list-style-type: none"> <li>1. Use clean cups and glasses.</li> <li>2. Do not use ice directly from freezer. Allow ice to become "wet" before using. Note; crushed ice also causes foaming of beverage. Carbonation is released on sharp edges of the ice.</li> </ol>
Water-to-syrup ratio to low or too high	<ol style="list-style-type: none"> <li>1.</li> <li>2.</li> <li>3.</li> </ol>	<ol style="list-style-type: none"> <li>1. Syrup flow regulator not properly adjusted.</li> <li>2. CO2 gas pressure in syrup tanks insufficient.</li> <li>3. Syrup tubing I.D. insufficient.</li> </ol>	<ol style="list-style-type: none"> <li>1.</li> <li>2.</li> <li>3.</li> </ol>	<ol style="list-style-type: none"> <li>1. Adjust water-to-syrup ratio (see dispensing station installation instructions.</li> <li>2. Adjust low pressure regulator as instructed.</li> <li>3. Increase syrup tubing I.D. Note: see "Brix instructions"</li> </ol>
Adjustment of syrup metering pin does not produce desired water-to-syrup ratio	<ol style="list-style-type: none"> <li>1.</li> <li>2.</li> <li>3.</li> <li>4.</li> <li>5.</li> <li>6.</li> </ol>	<ol style="list-style-type: none"> <li>1. No syrup supply.</li> <li>2. Syrup tank quick disconnects not secure.</li> <li>3. Low pressure CO2 regulator out of adjustment.</li> <li>4. B.I.B. QCD disconnected or improperly installed.</li> <li>5. Syrup line restricted.</li> <li>6. Dirty or inoperative metering pin or piston in syrup flow control.</li> </ol>	<ol style="list-style-type: none"> <li>1.</li> <li>2.</li> <li>3.</li> <li>4.</li> <li>5.</li> <li>6.</li> </ol>	<ol style="list-style-type: none"> <li>1. Replenish syrup supply as instructed.</li> <li>2. Secure quick disconnects.</li> <li>3. Adjust low pressure CO2 regulator as instructed.</li> <li>4. Connect B.I.B. disconnect securely.</li> <li>5. Clear restriction or replace restricted line.</li> <li>6. Disassemble and clean syrup flow control. Adjust water-to-syrup ratio, see "Brix instruction".</li> </ol>

# CARBONATION TROUBLE SHOOTING FLOW CHART #1

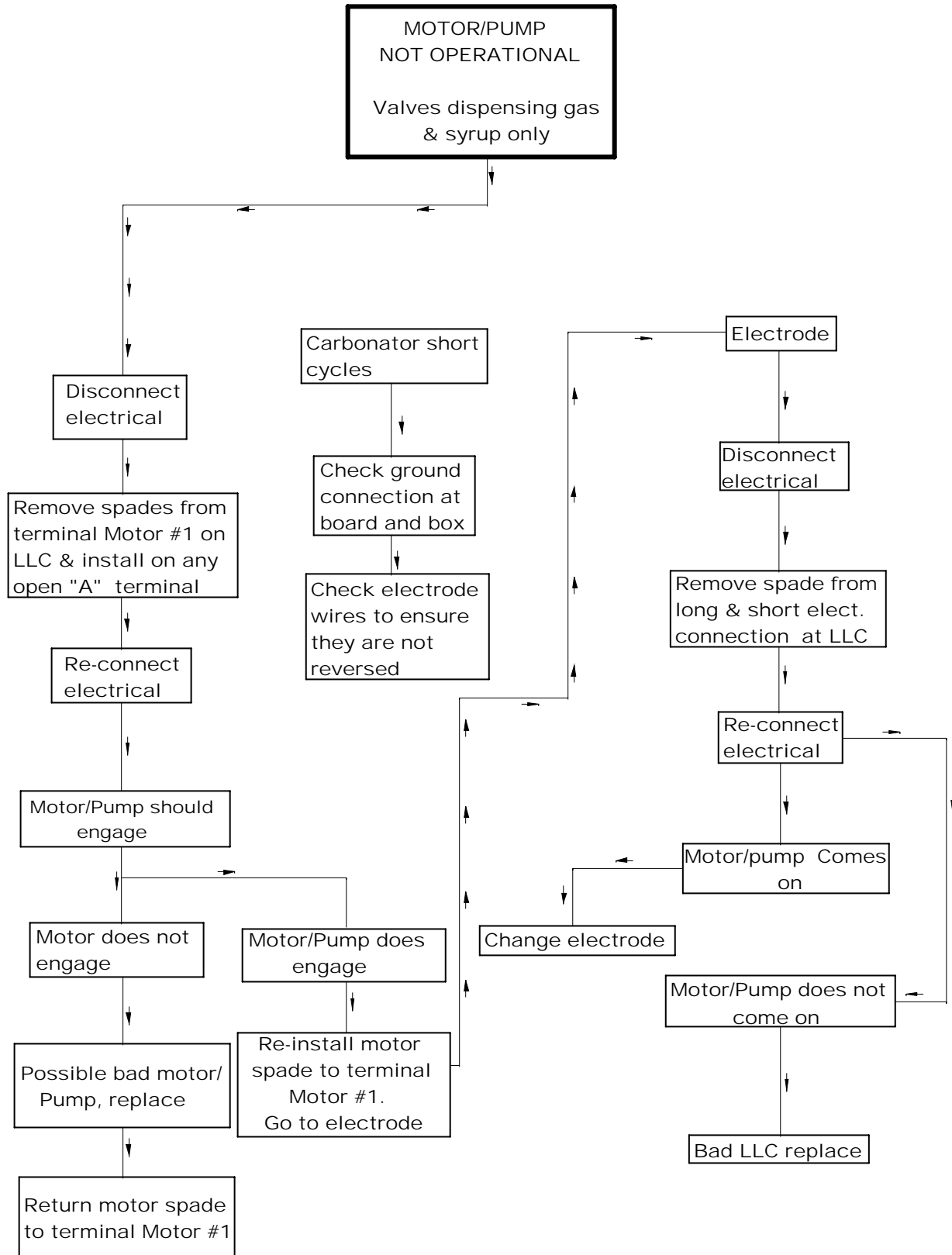

## CARBONATION TROUBLE SHOOTING FLOW CHART #2

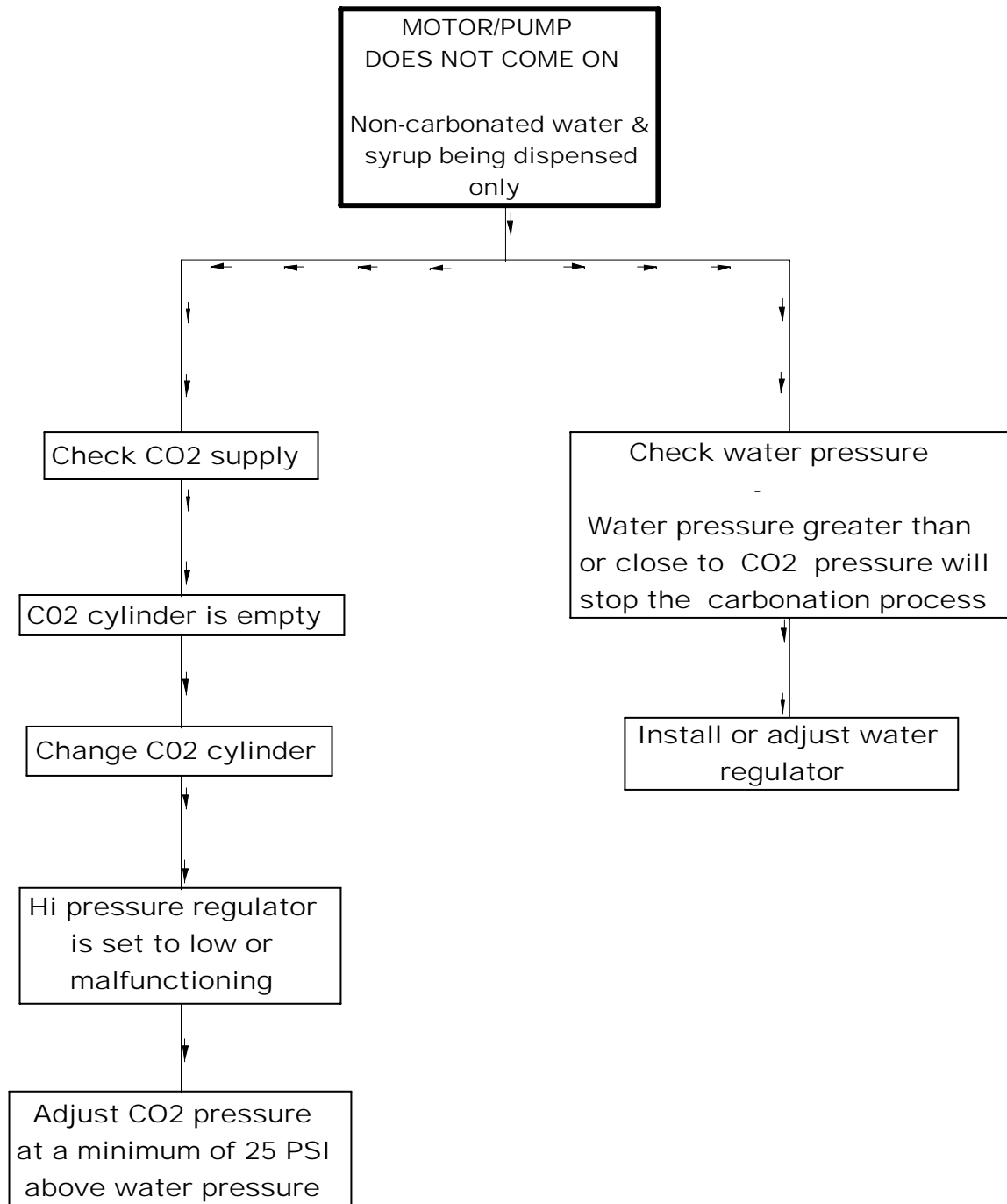

# CARBONATION TROUBLE SHOOTING FLOW CHART #3

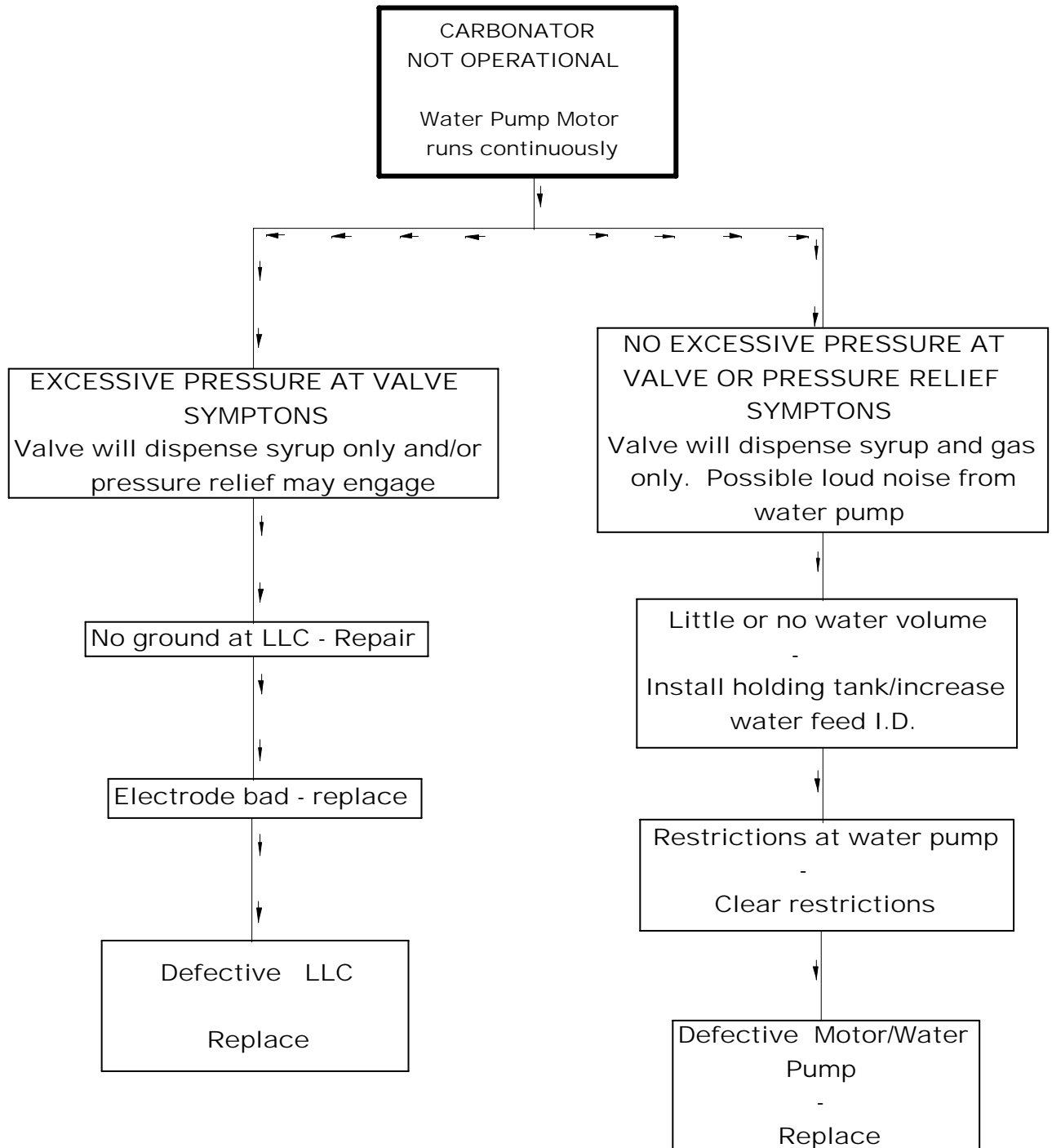

NOTE SECTION

Frequently Called Numbers:

<hr/>	<hr/>
<hr/>	<hr/>
<hr/>	<hr/>
<hr/>	<hr/>
<hr/>	<hr/>
<hr/>	<hr/>

CO2 SETTINGS:

High Pressure \_\_\_\_\_ PSI  
Low Pressure \_\_\_\_\_ PSI

Product Setup:

#1		#2
<hr/>		<hr/>
<hr/>		<hr/>
<hr/>		<hr/>
<hr/>		<hr/>
<hr/>		<hr/>
<hr/>		<hr/>
<hr/>		<hr/>
<hr/>		<hr/>
<hr/>		<hr/>
<hr/>		<hr/>
<hr/>		<hr/>
<hr/>		<hr/>
<hr/>		<hr/>
<hr/>		<hr/>
<hr/>		<hr/>
<hr/>		<hr/>
<hr/>		<hr/>
<hr/>		<hr/>
<hr/>		<hr/>
<hr/>		<hr/>
<hr/>		<hr/>
<hr/>		<hr/>
<hr/>		<hr/>